

Suzu_001

Suzuki Alto 3-Tuerer

1:30 L: 3.495 B: 1.495 H: 1.405 R: 2.335

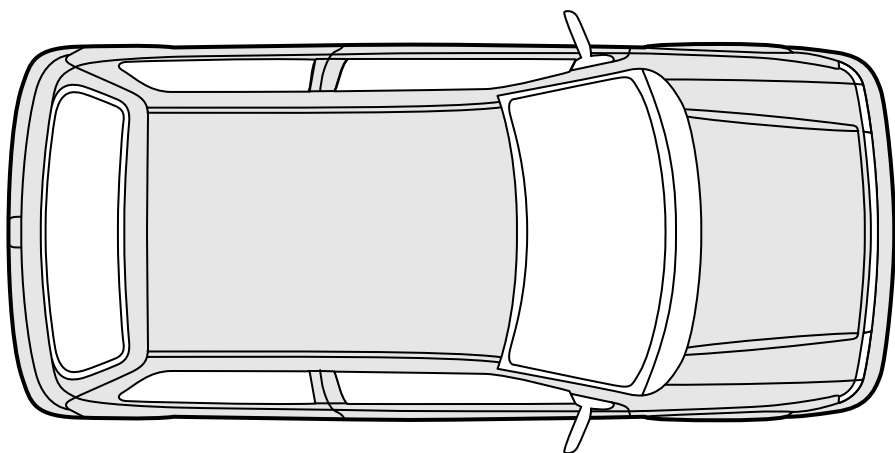
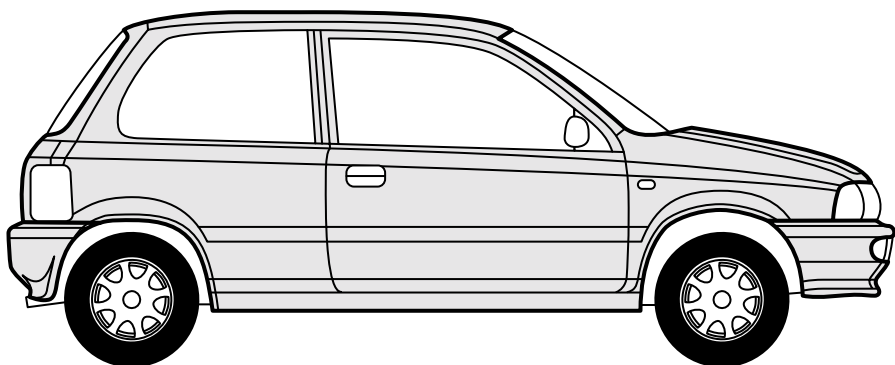
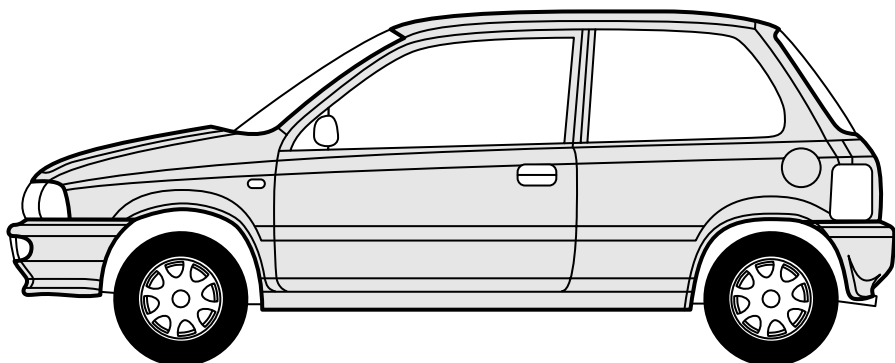
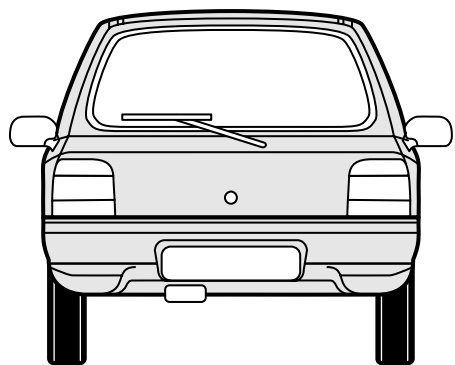
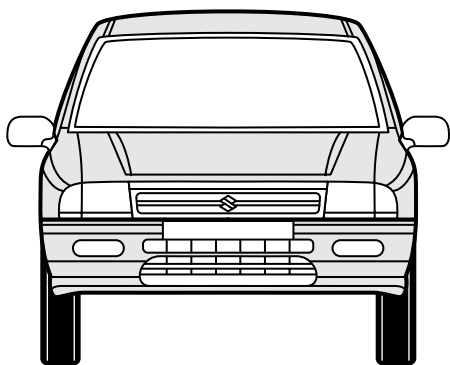

Suzu_004

Suzuki Baleno 3-Tuerer, GS (1997)

1:30 L: 3.900 B: 1.690 H: 1.395 R: 2.380

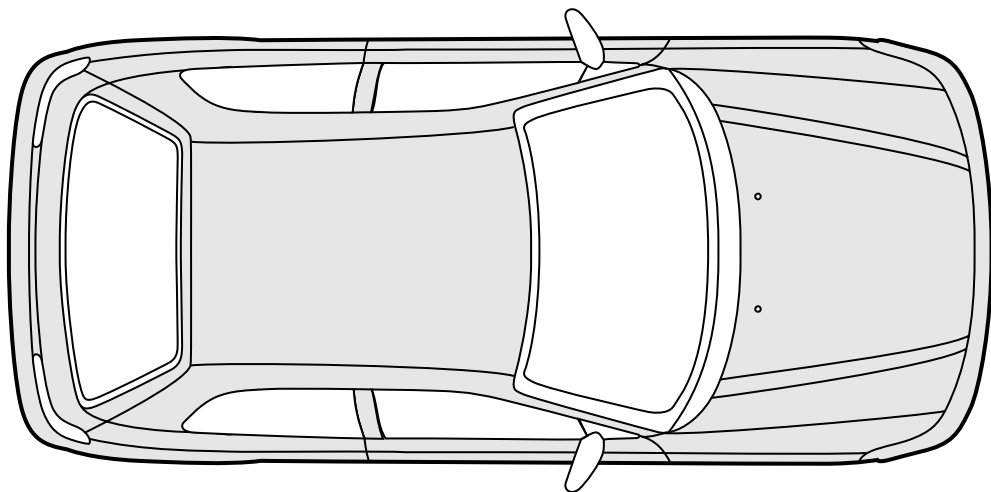
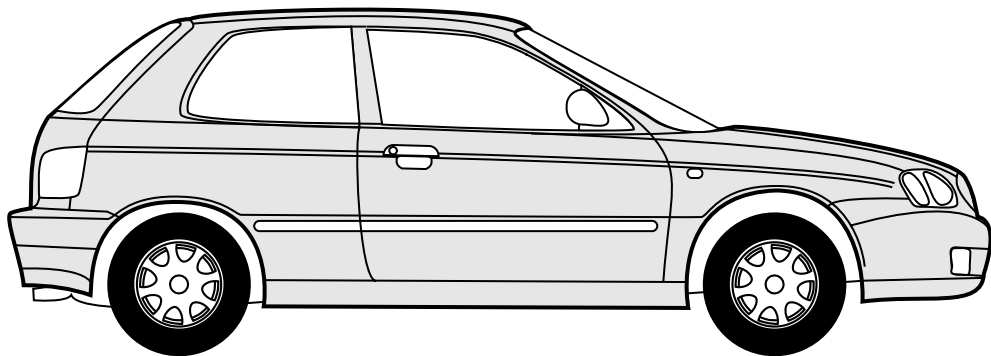
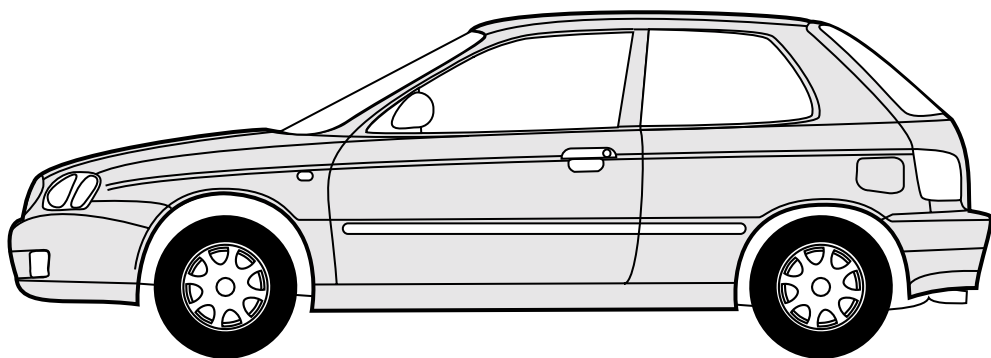
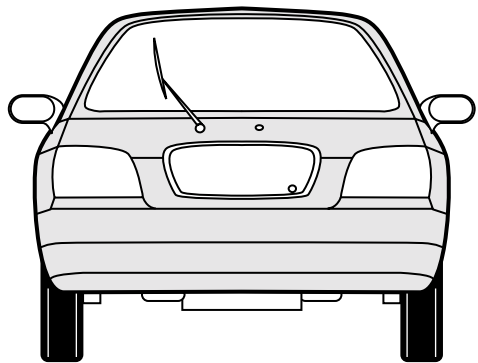
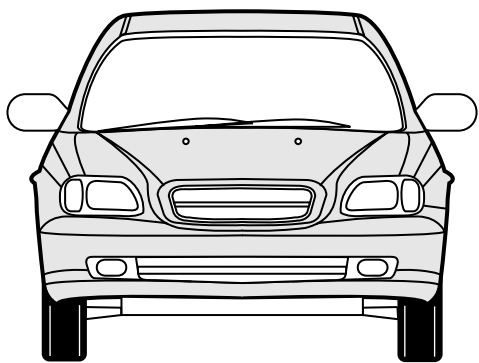

Suzu_003

Suzuki Baleno 3-Tuerer, Hatchback

1:30 L: 3.870 B: 1.690 H: 1.395 R: 2.380

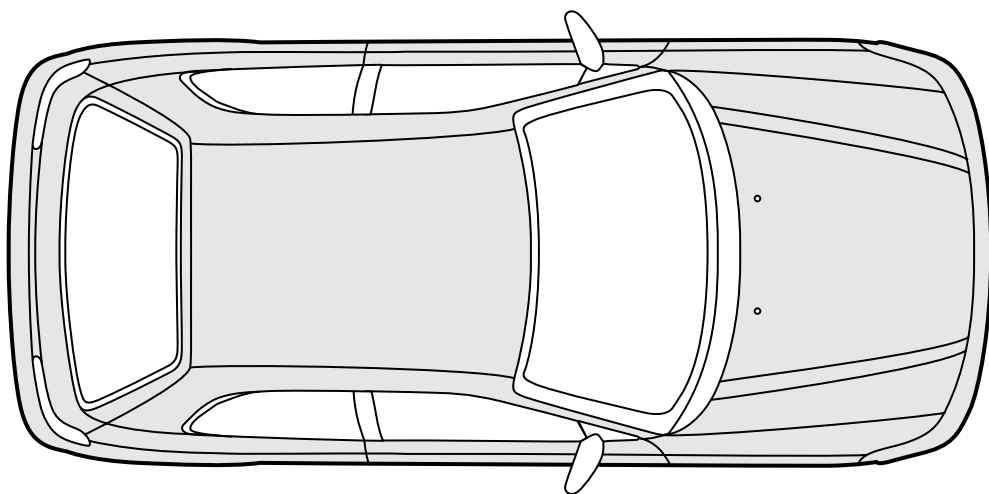
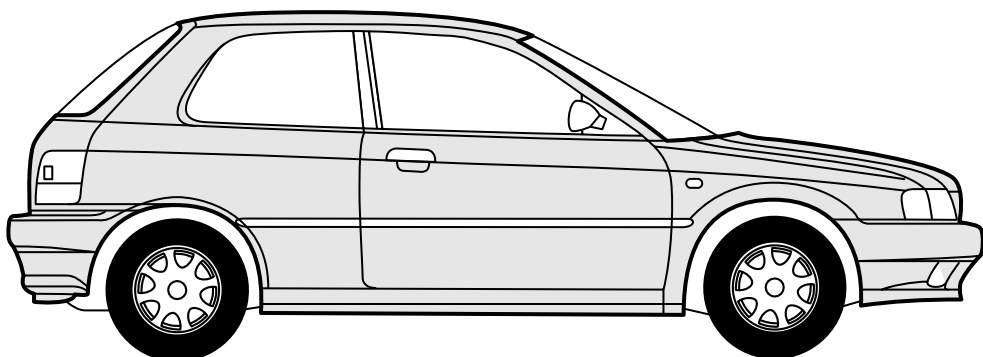
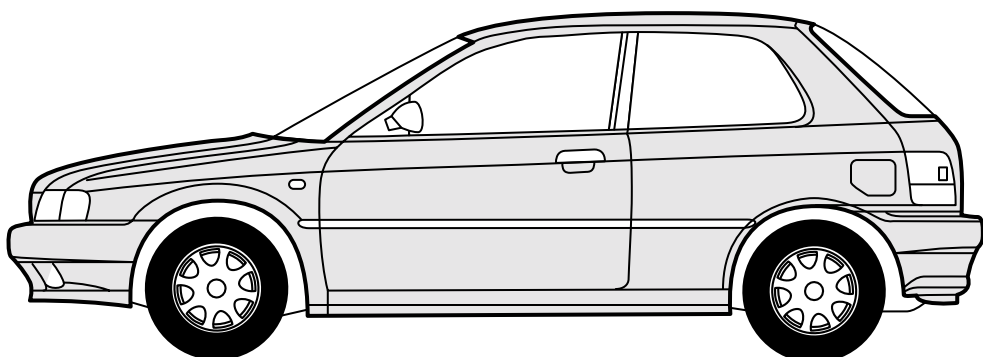
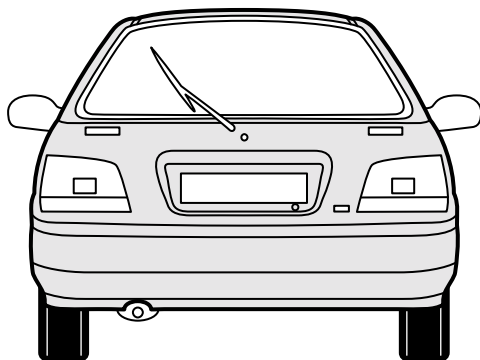
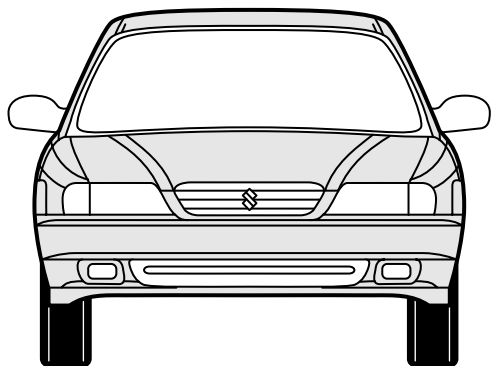

Suzu_002

Suzuki Alto 5-Tuerer

1:30 L: 3.495 B: 1.495 H: 1.405 R: 2.335

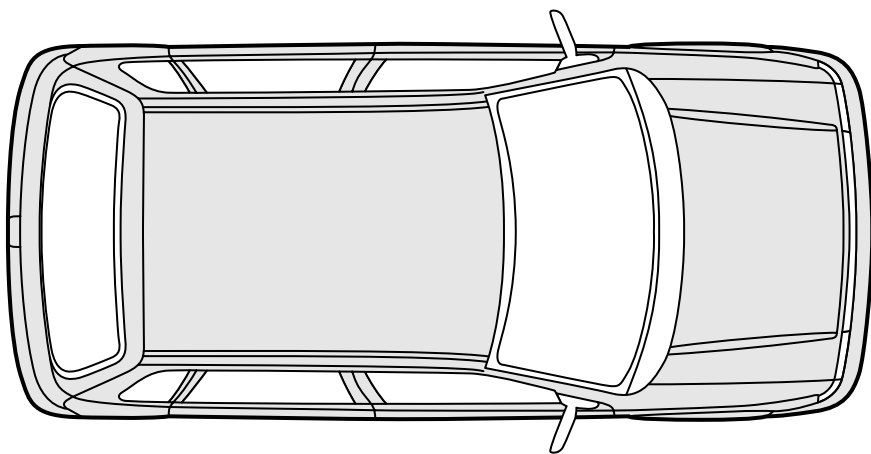
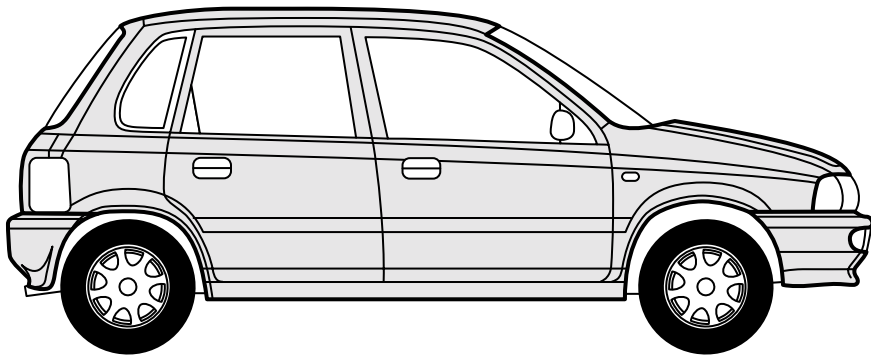
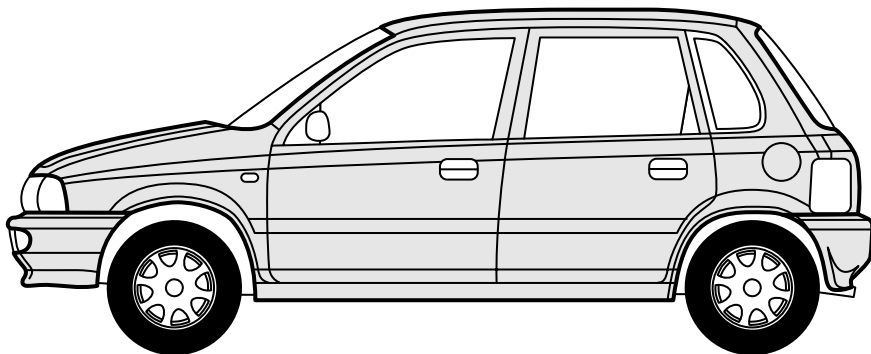
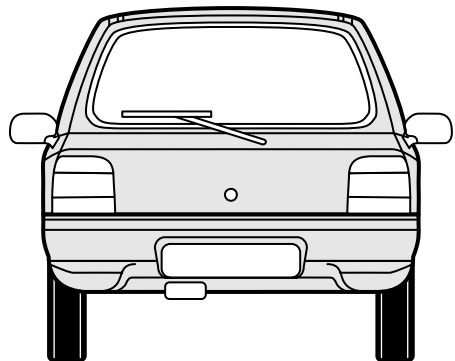
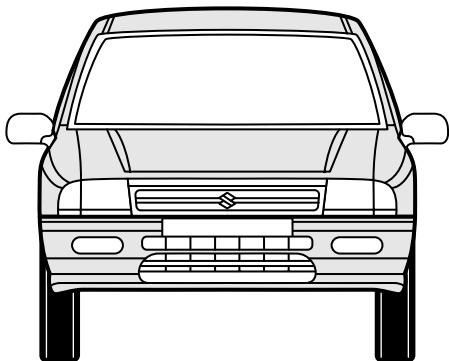

Suzu_005

Suzuki Baleno 4-Tuerer, Sedan

1:30 L: 4.195 B: 1.690 H: 1.390 R: 2.480

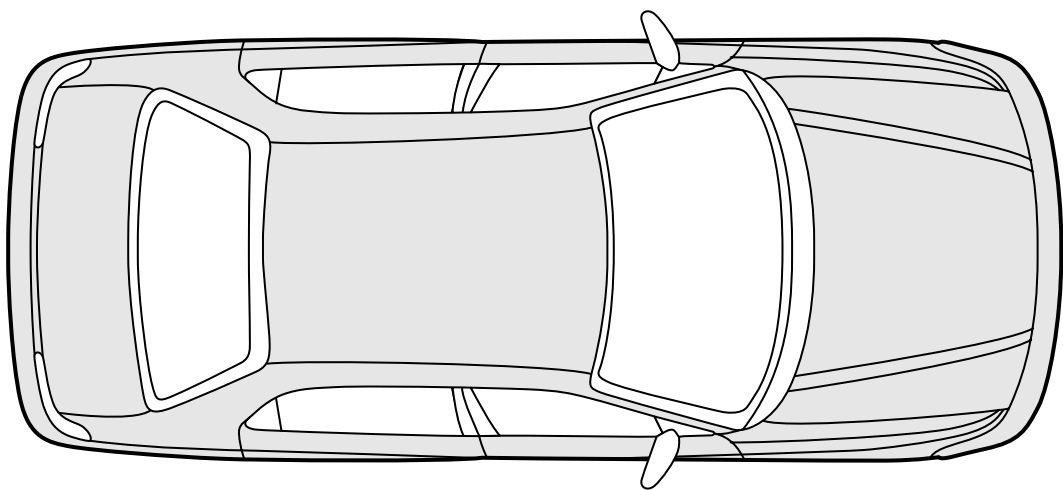
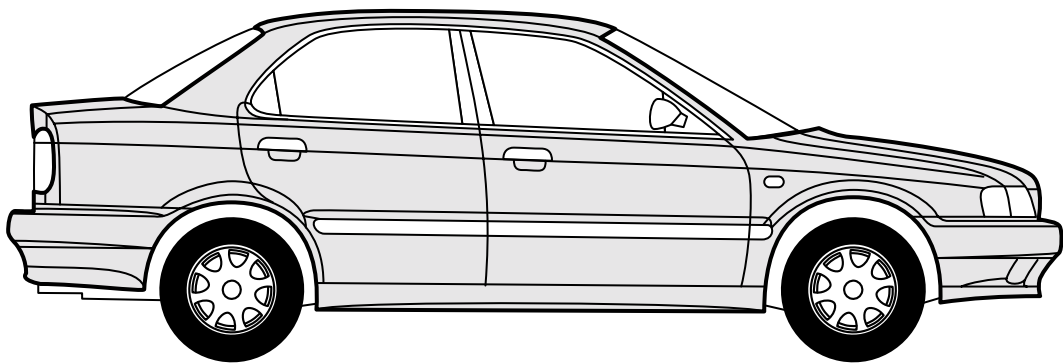
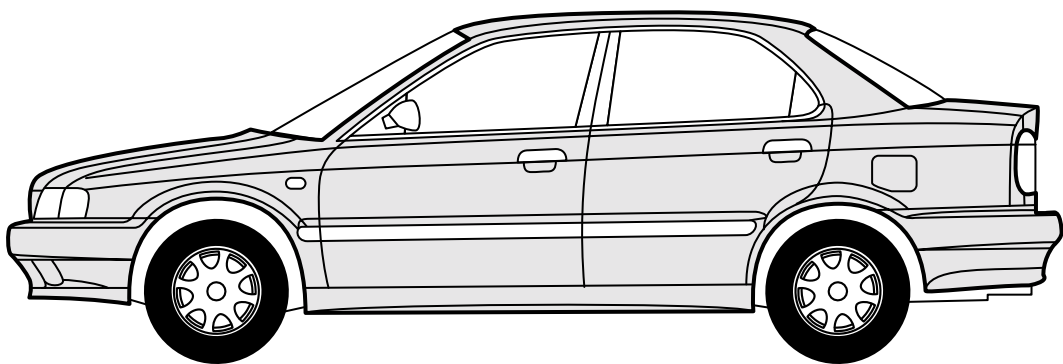
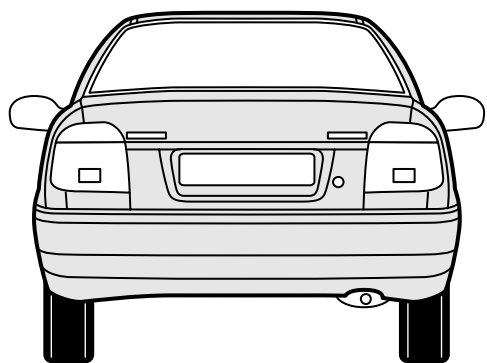
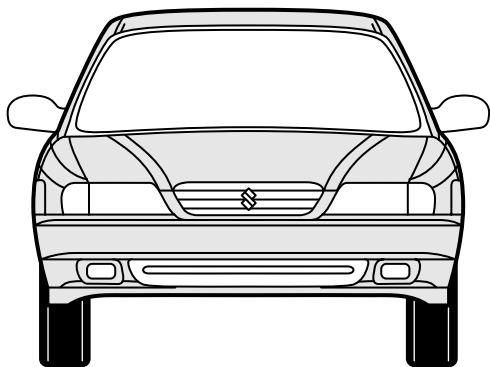

Suzu_006

Suzuki Baleno Kombi

1:30 L: 4.345 B: 1.690 H: 1.460 R: 2.480

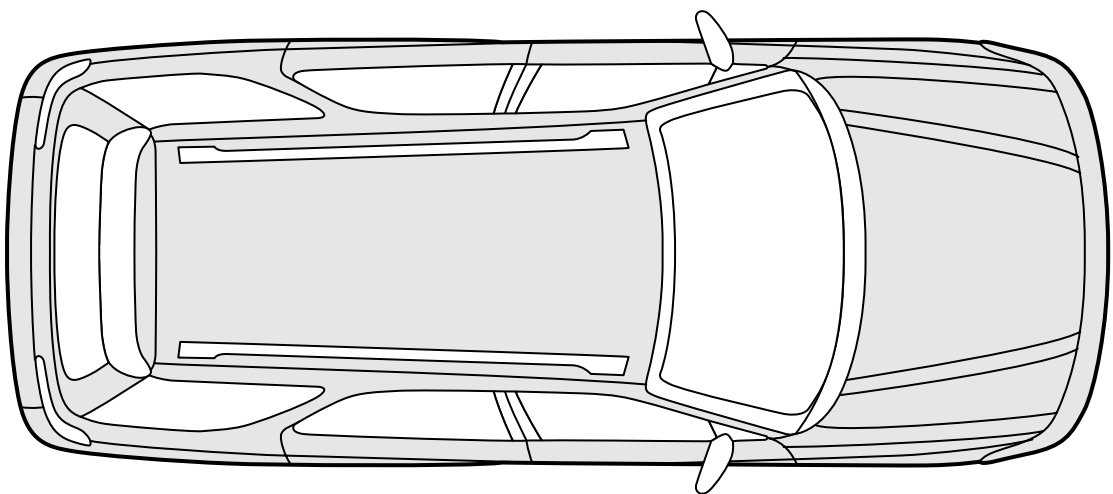
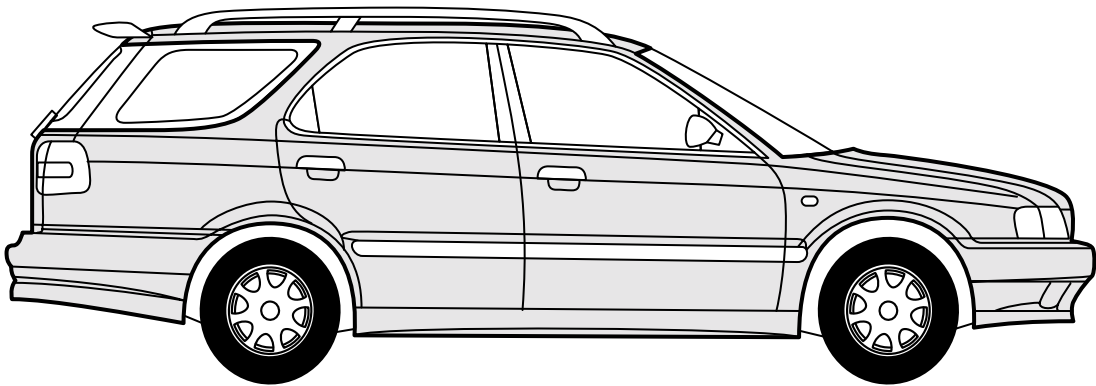
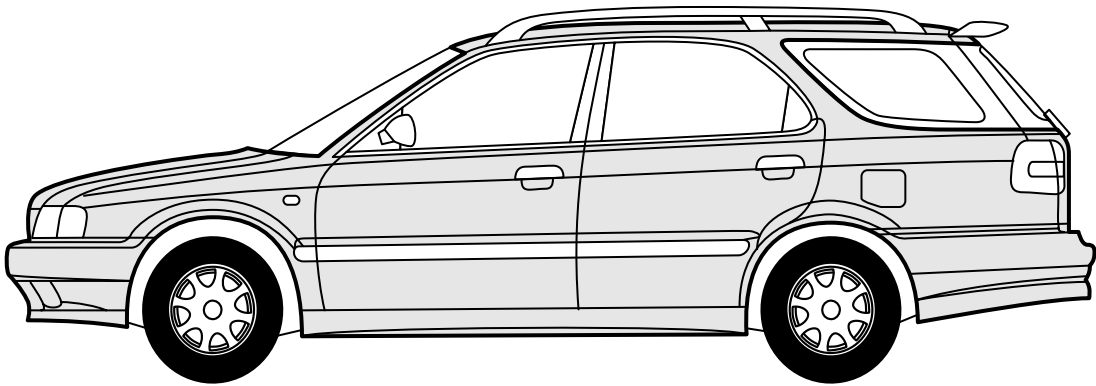
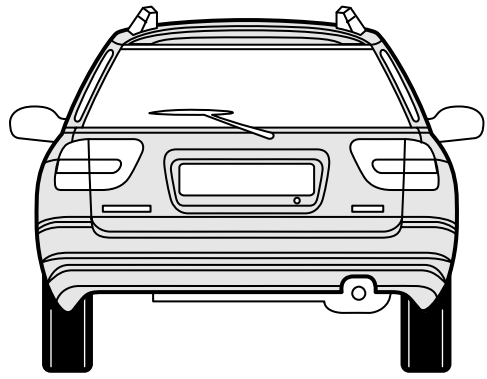
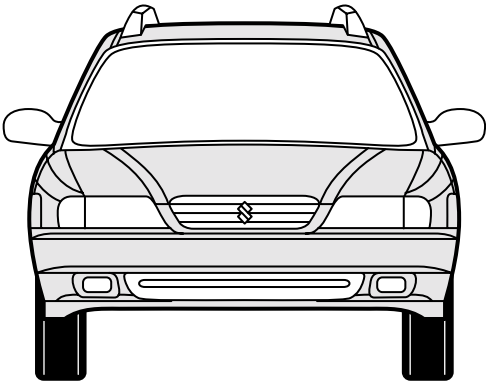

Suzu_007

Suzuki Baleno Kombi (1997)

1:30 L: 4.375 B: 1.690 H: 1.460 R: 2.480

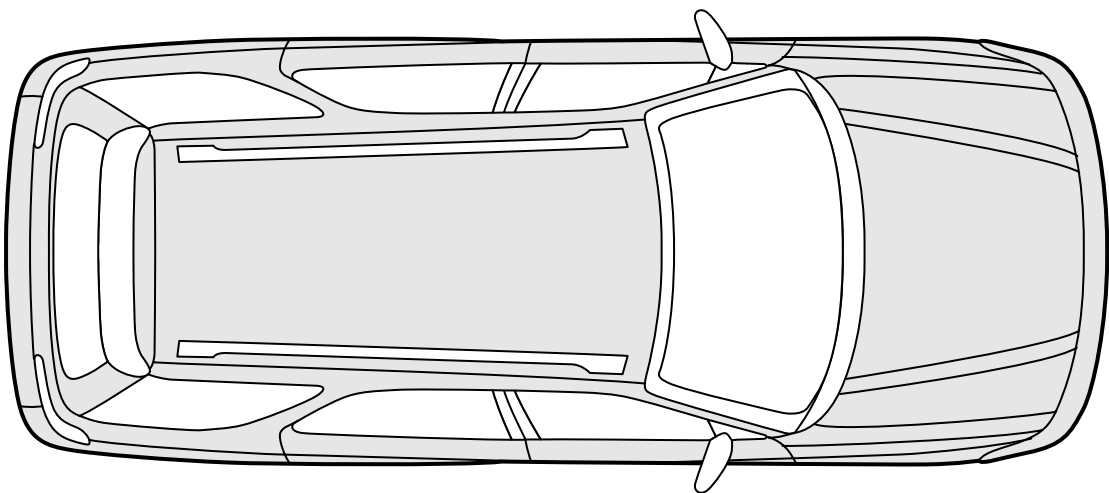
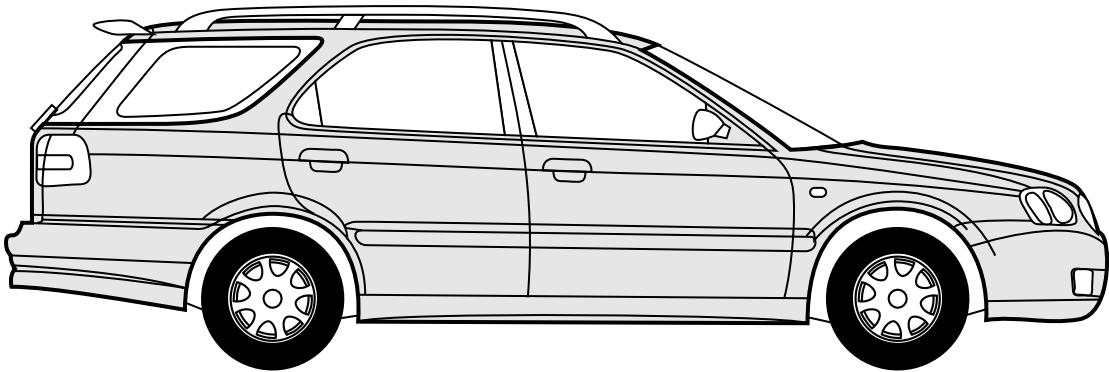
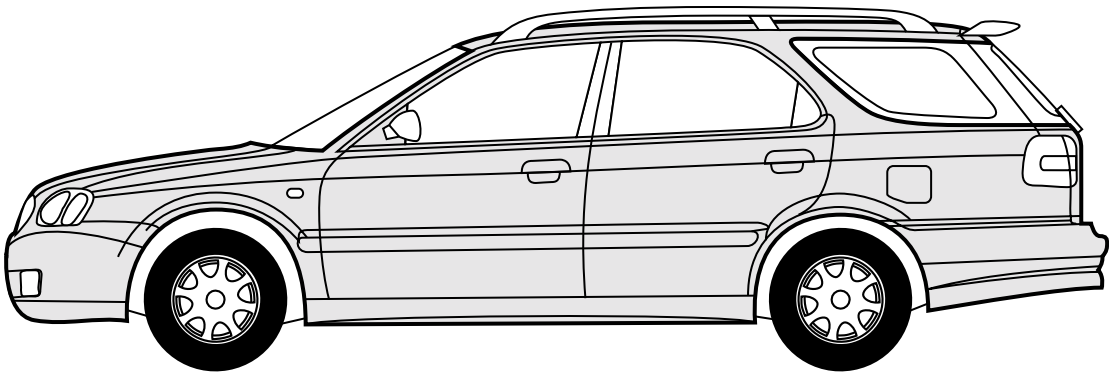
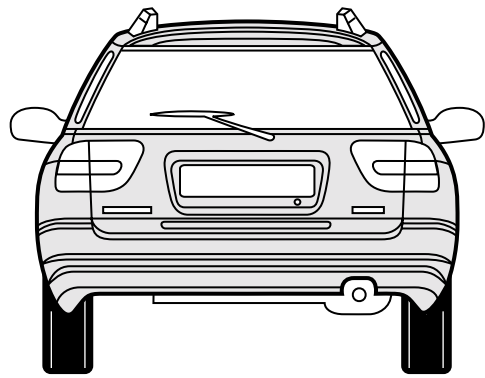
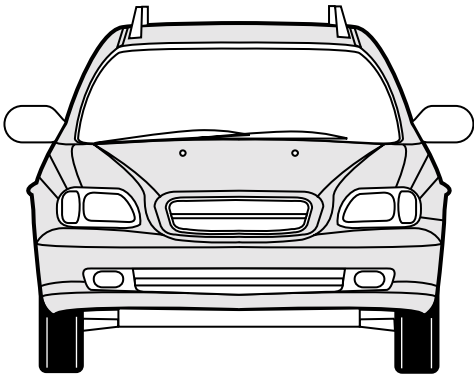

Suzu_008

Suzuki Carry

1:30 L: 3.295 B: 1.395 H: 1.780 R: 1.840

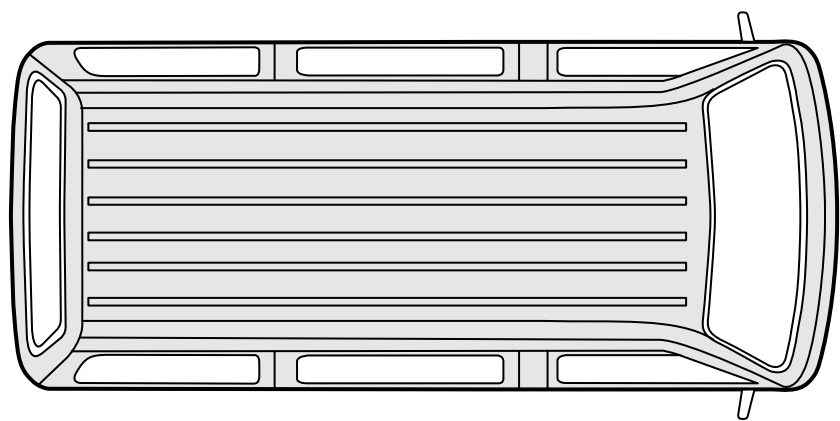
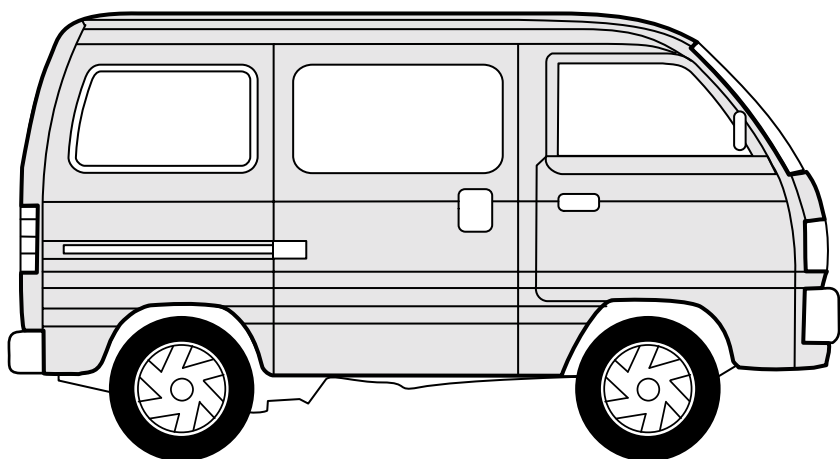
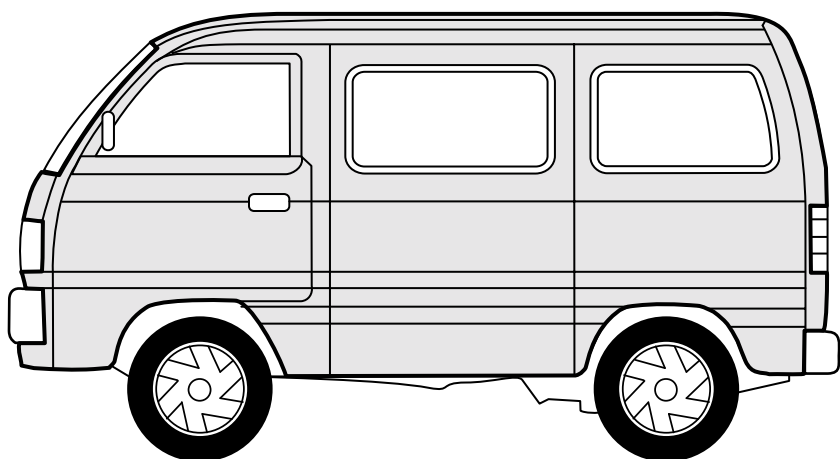
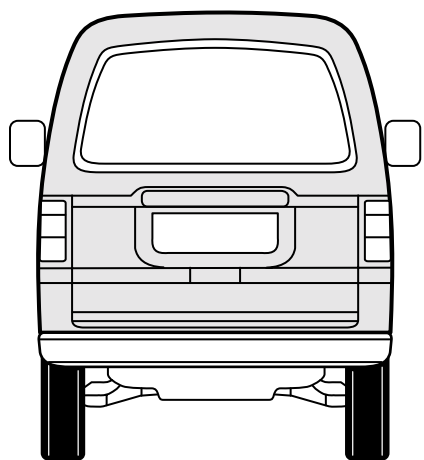
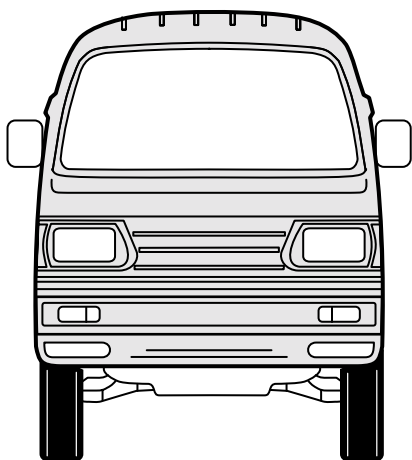

Suzu_009

Suzuki Carry, 3-Tuerer + 2 Schiebetueren (1999)

1:30 L: 3.675 B: 1.475 H: 1.800 R: 2.350

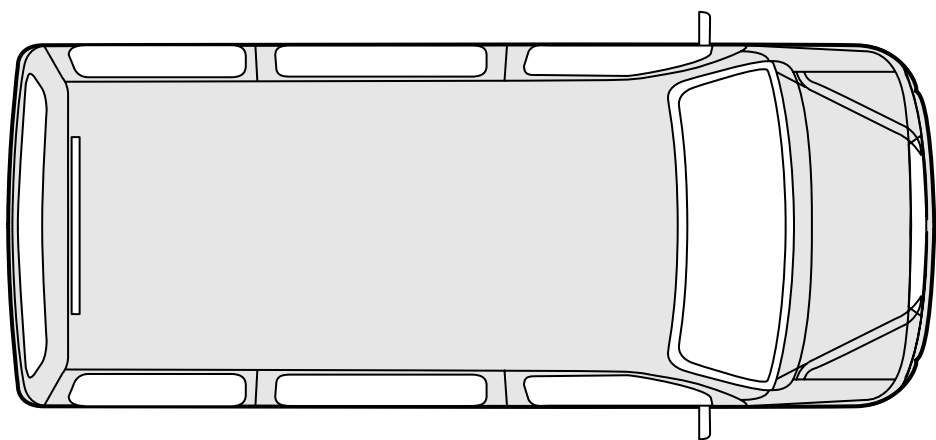
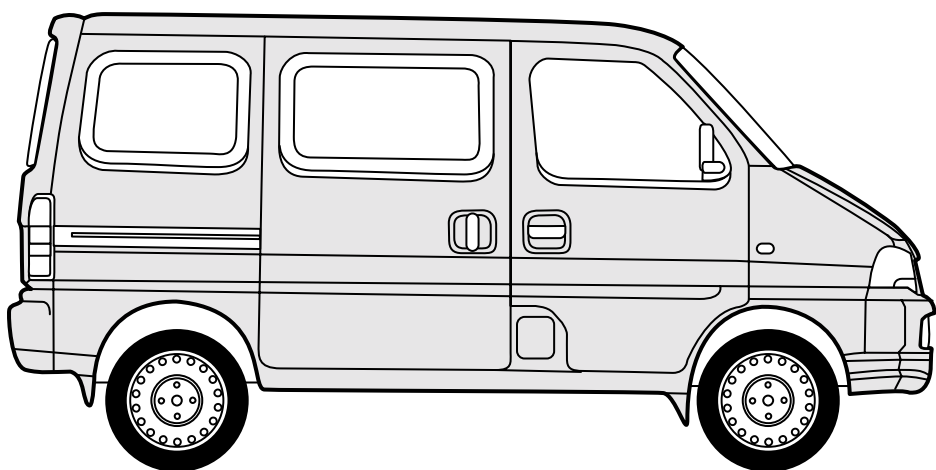
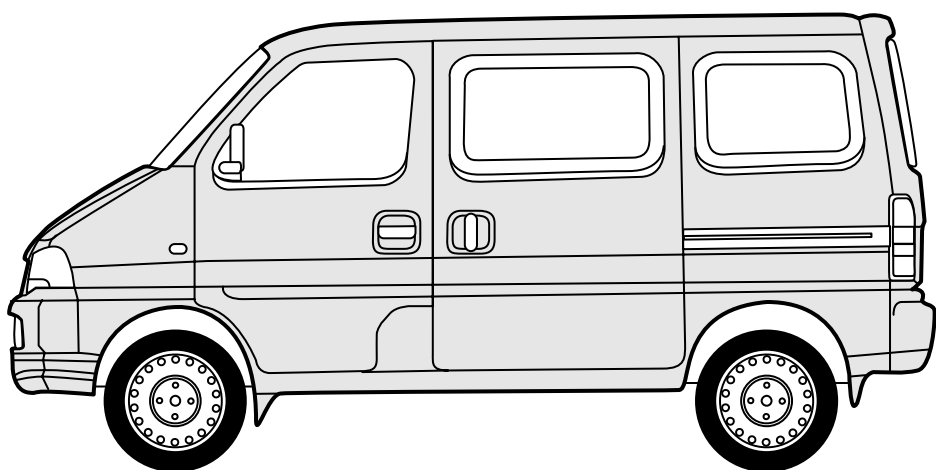
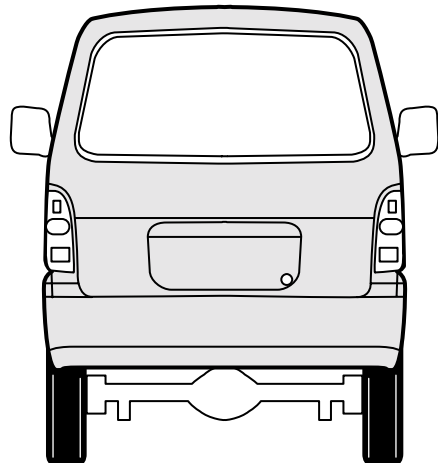
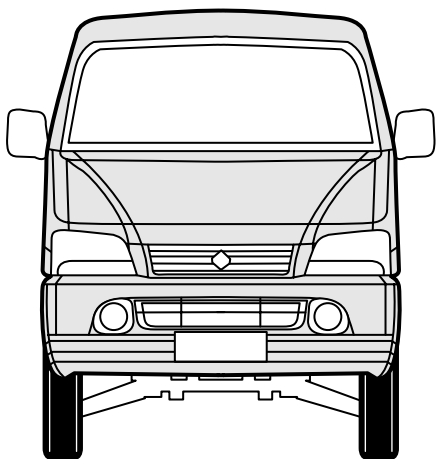

Suzu_010

Suzuki Grand Vitara Limousine 2.0, 3-Tuerer

1:30 L: 3.885 B: 1.695 H: 1.685 R: 2.200

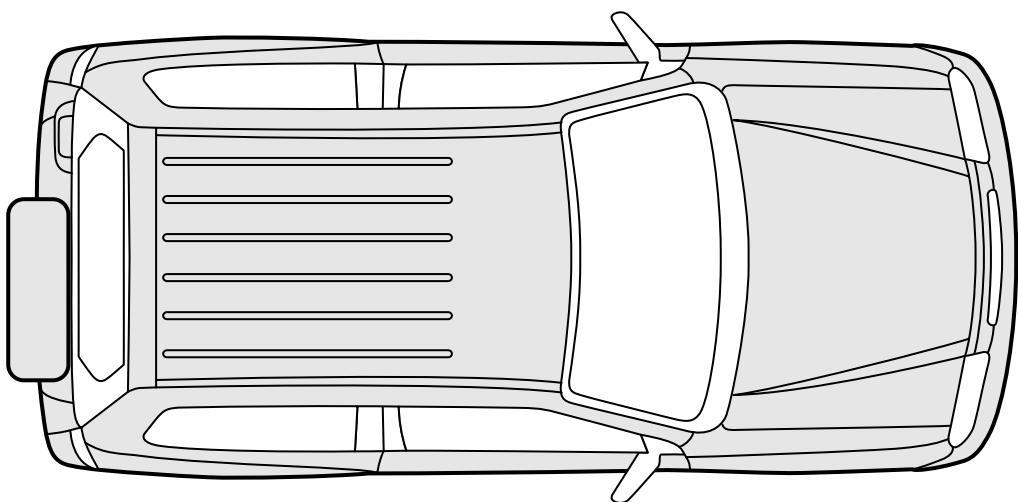
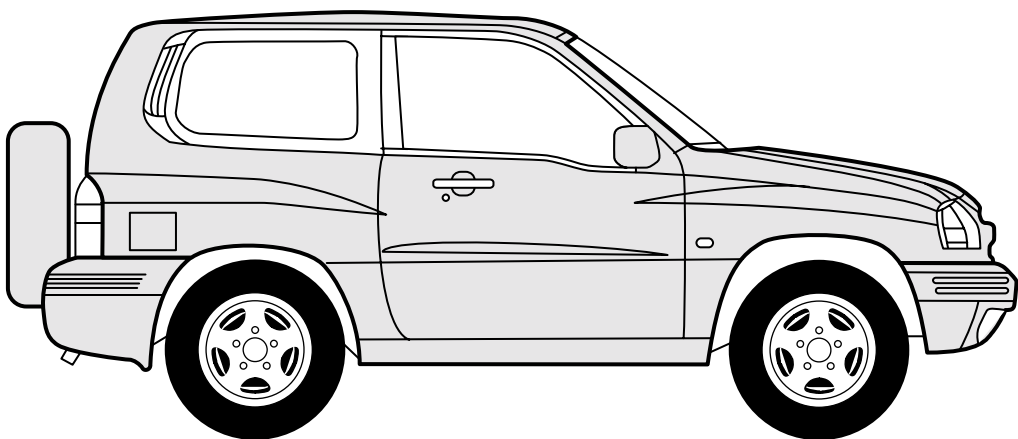
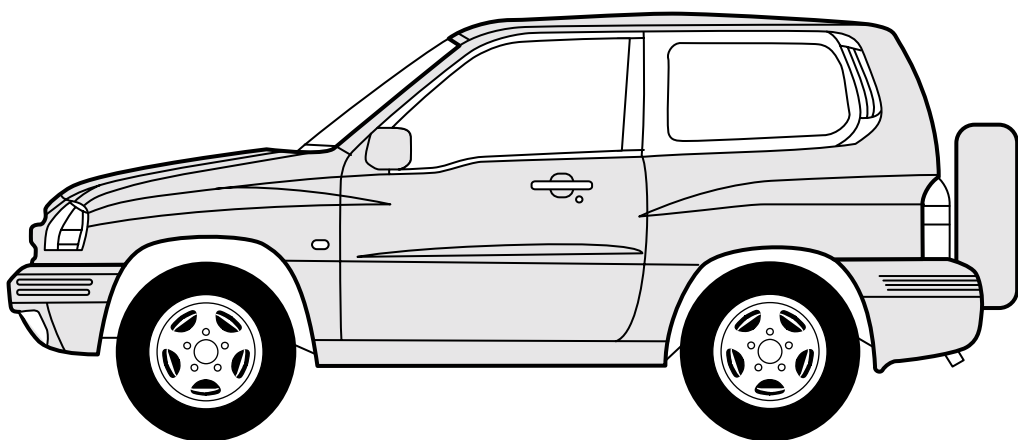
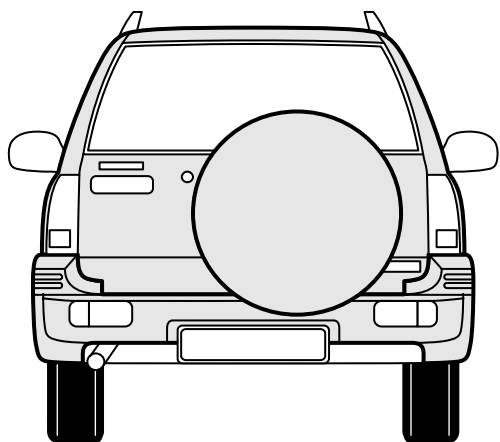
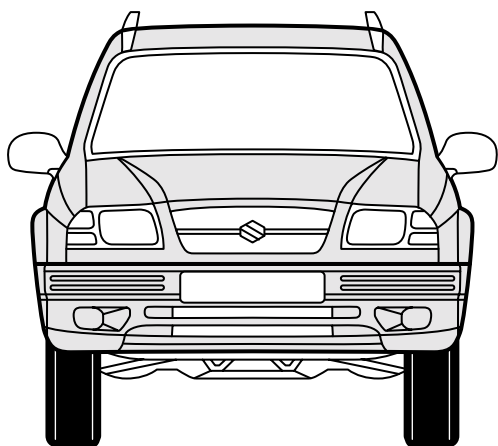

Suzu_011

Suzuki Grand Vitara, 5-Tuerer

1:30 L: 4.195 B: 1.780 H: 1.685 R: 2.480

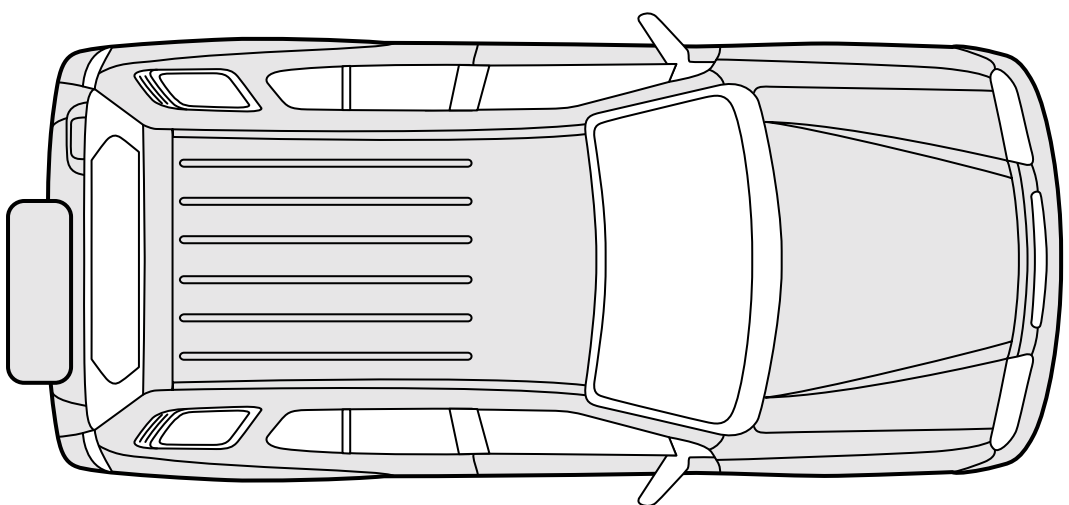
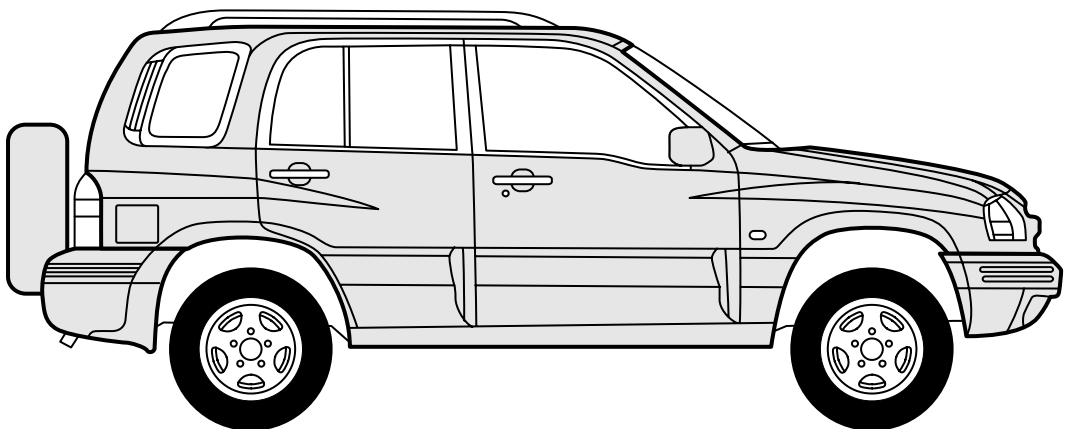
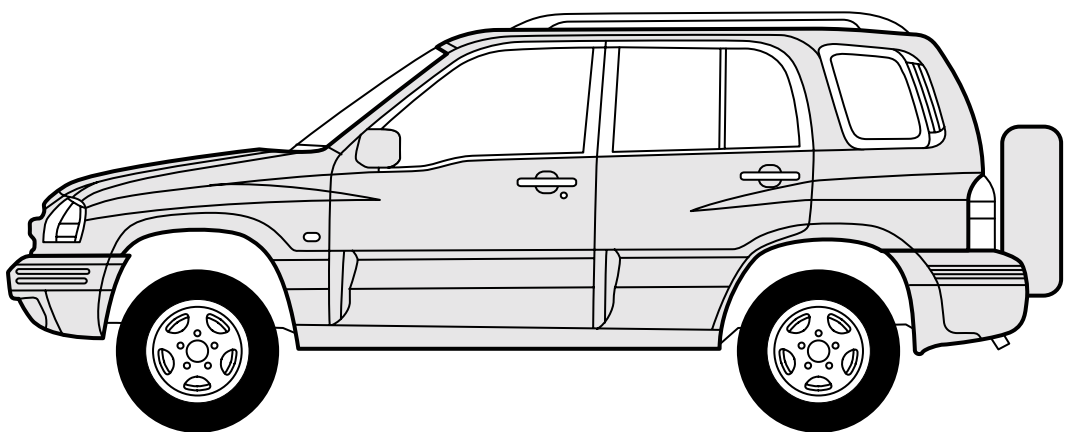
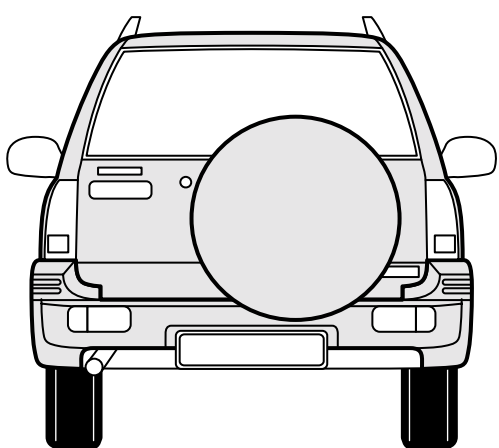
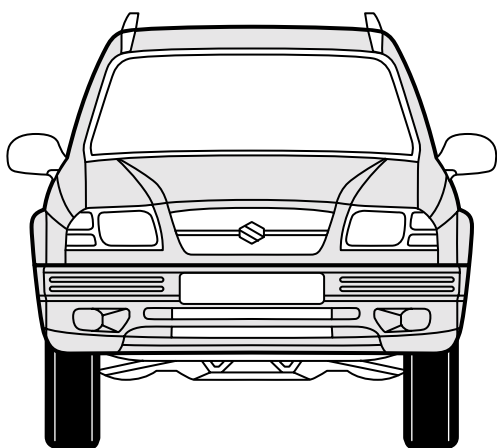

Suzu_012

Suzuki Jimny mit «Cross-Country» - Packet

1:30 L: 3.625 B: 1.600 H: 1.705 R: 2.250

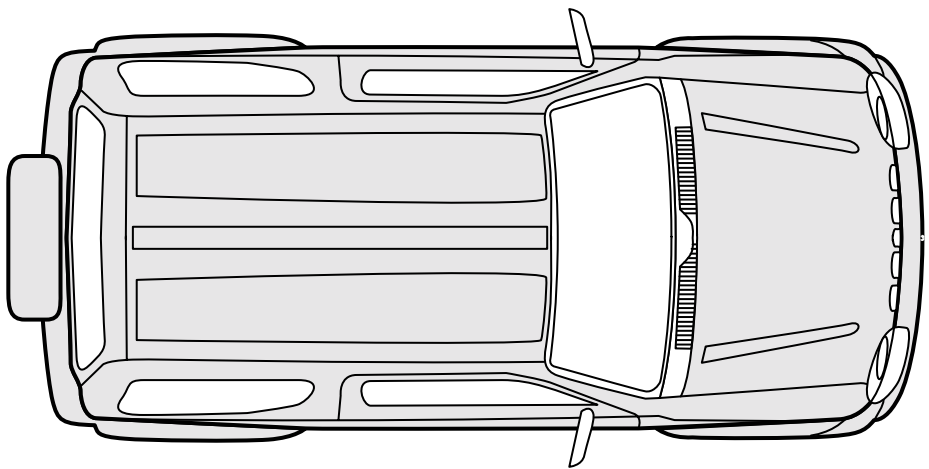
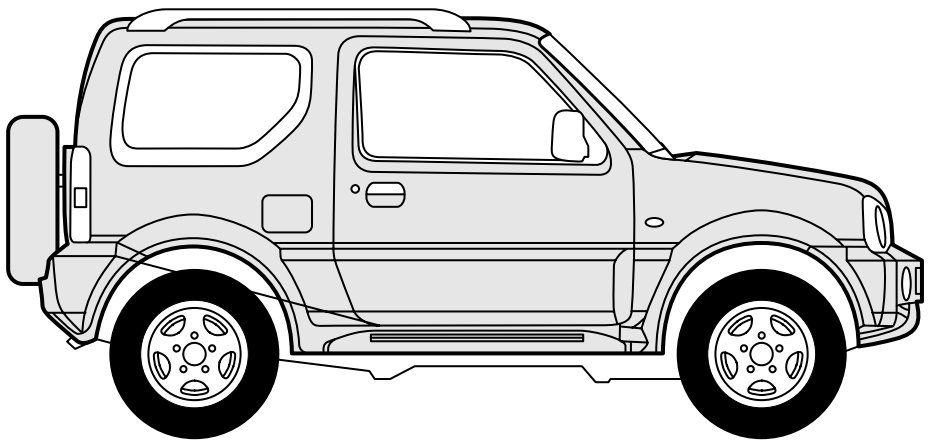
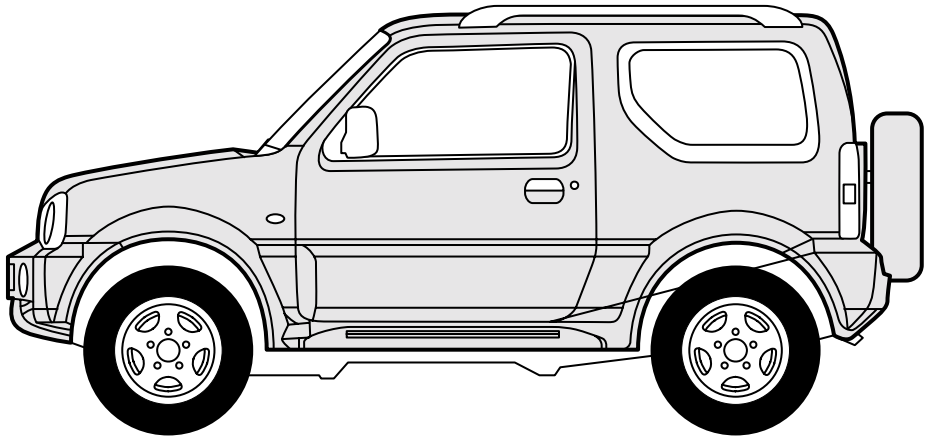
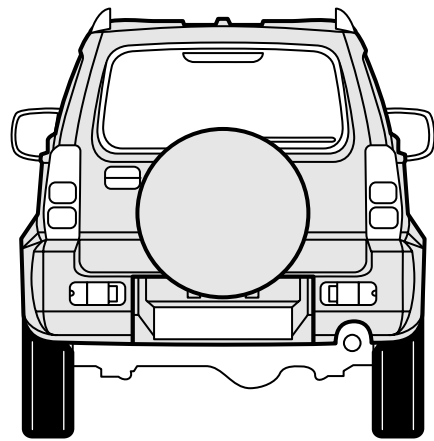

Suzu_013

Suzuki Samurai Cabrio

1:30 L: 3.430 B: 1.540 H: 1.665 R: 2.030

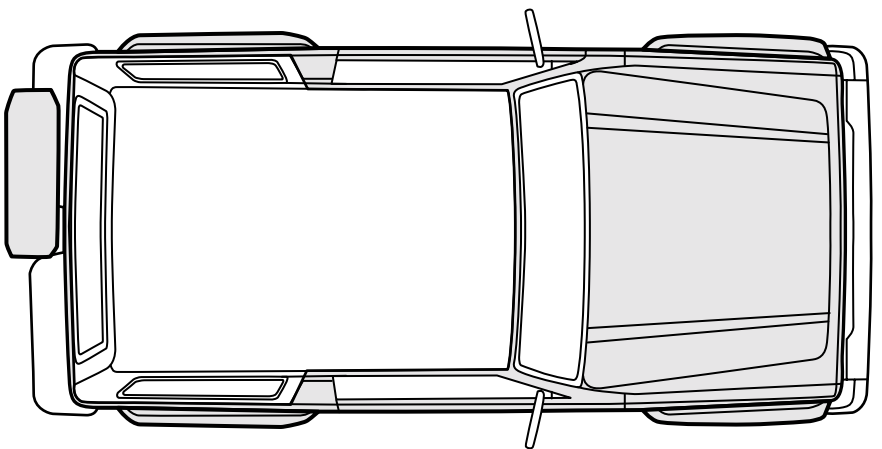
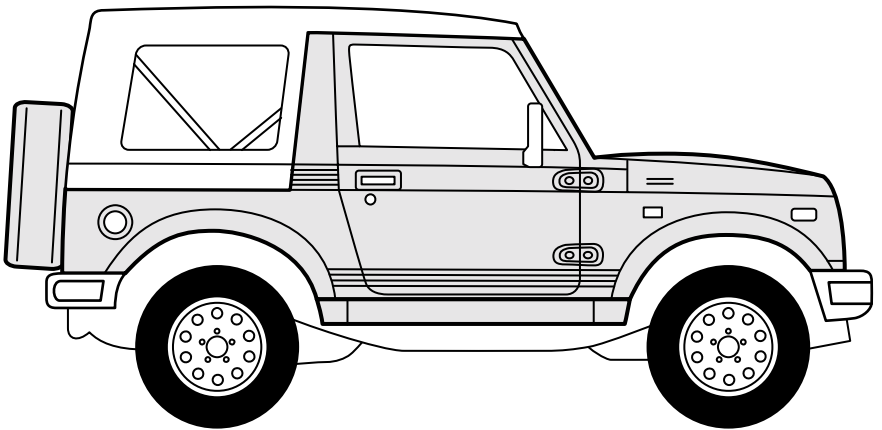
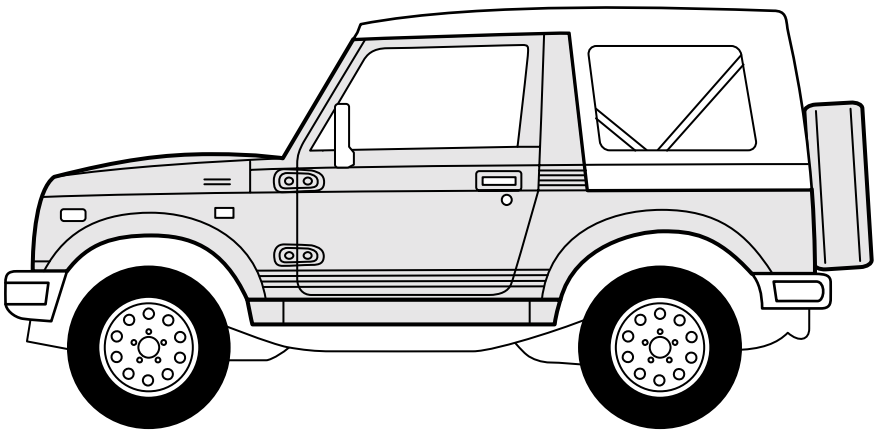
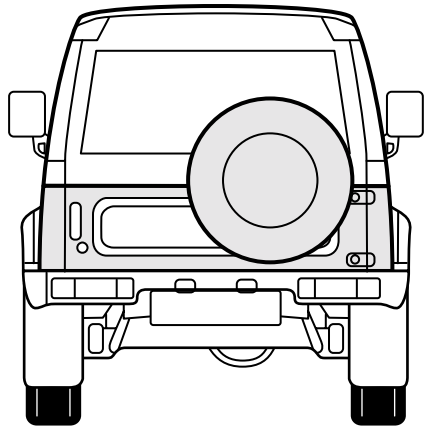
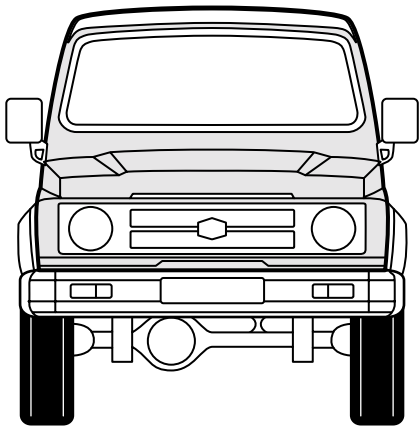

Suzu_014

Suzuki Samurai Wagon

1:30 L: 3.440 B: 1.540 H: 1.675 R: 2.030

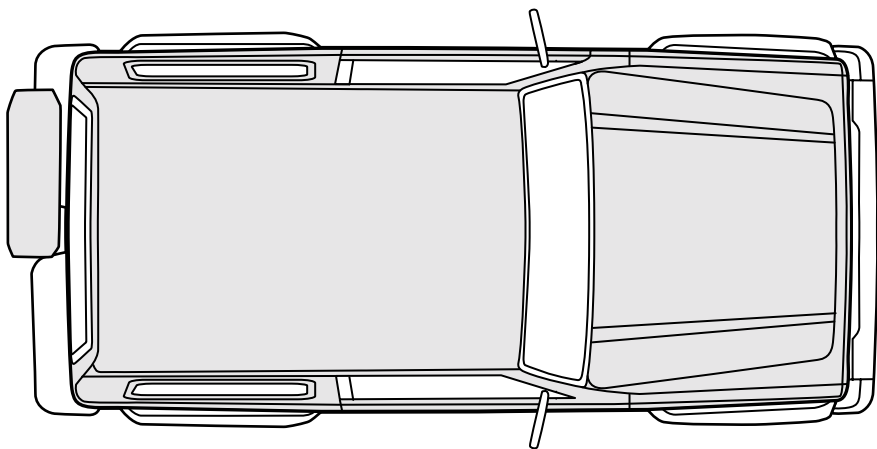
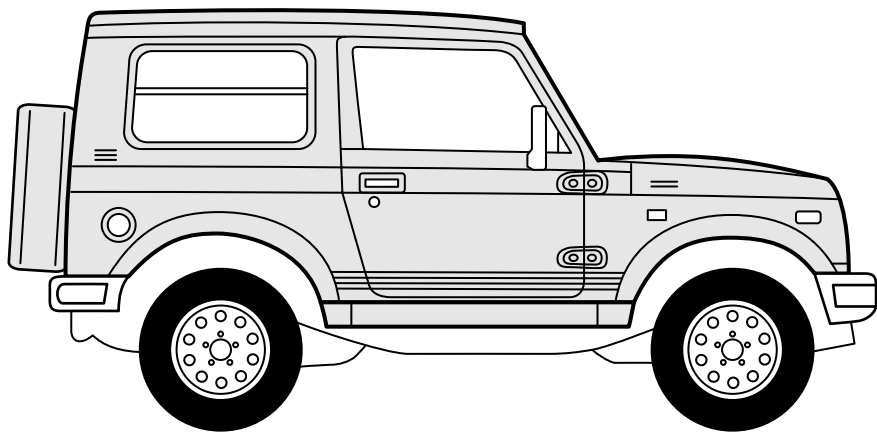
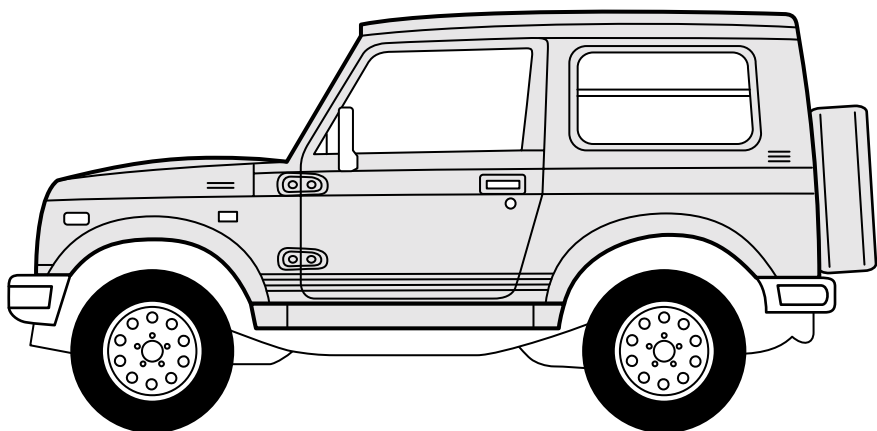
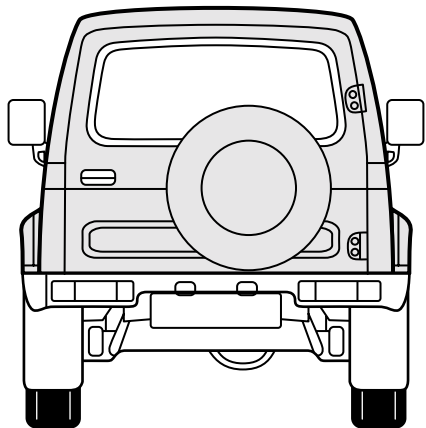
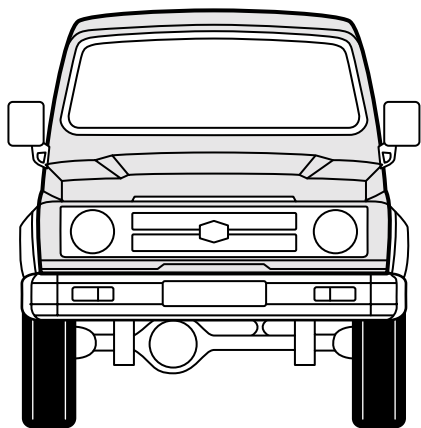

Suzu_015

Suzuki Swift 3-Tuerer

1:30 L: 3.745 B: 1.575 H: 1.350 R: 2.265

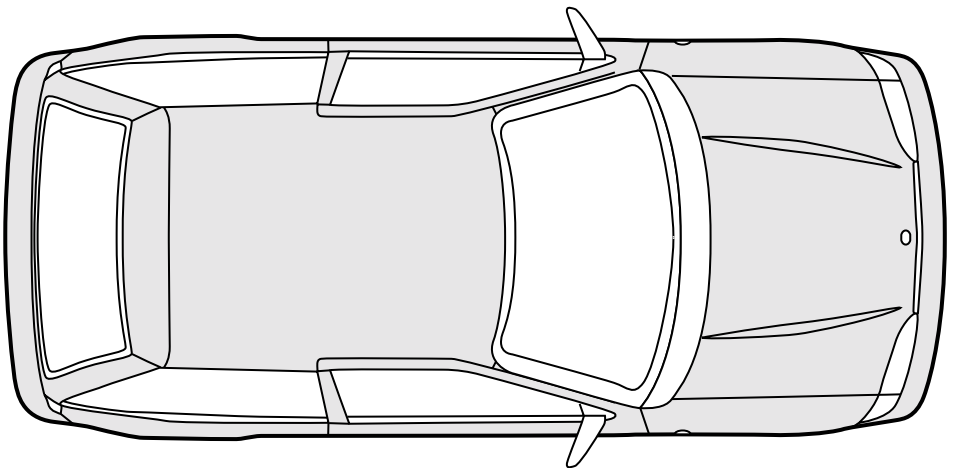
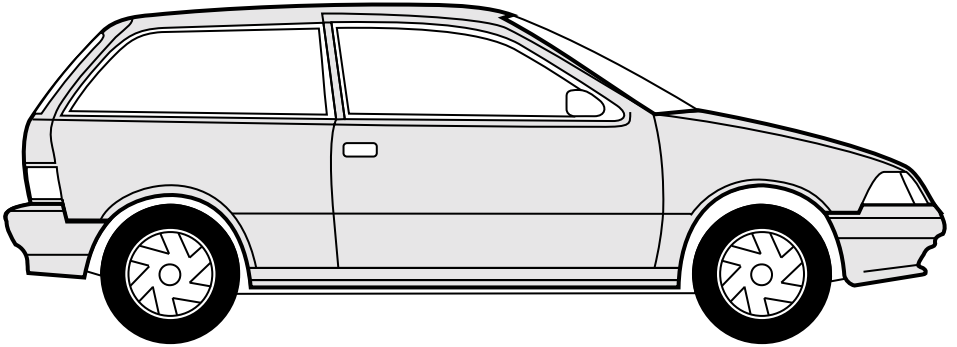
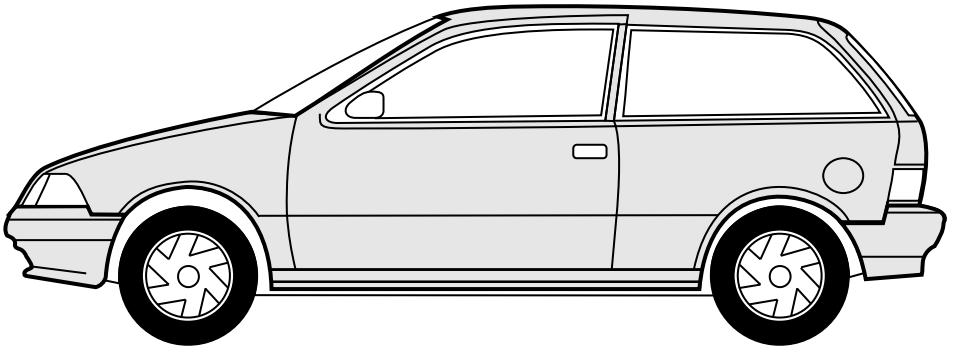
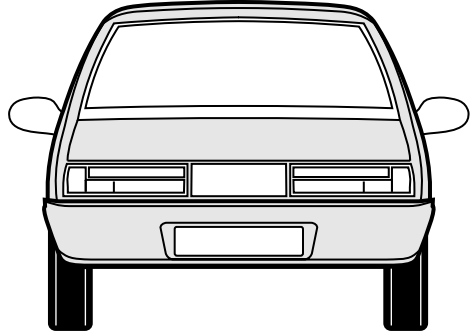
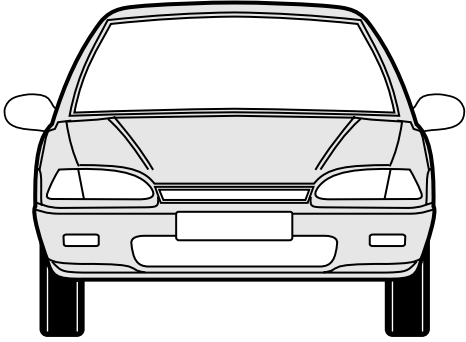

Suzu_016

Suzuki Swift 5-Tuerer

1:30 L: 3.845 B: 1.575 H: 1.380 R: 2.365

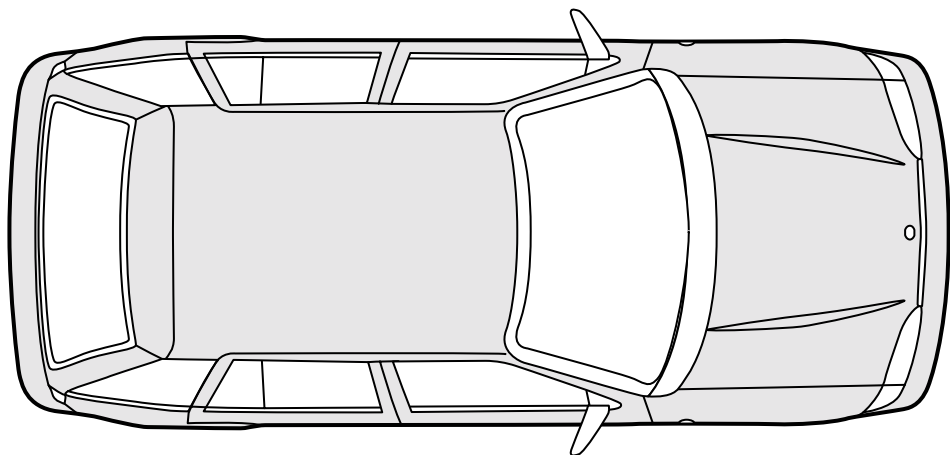
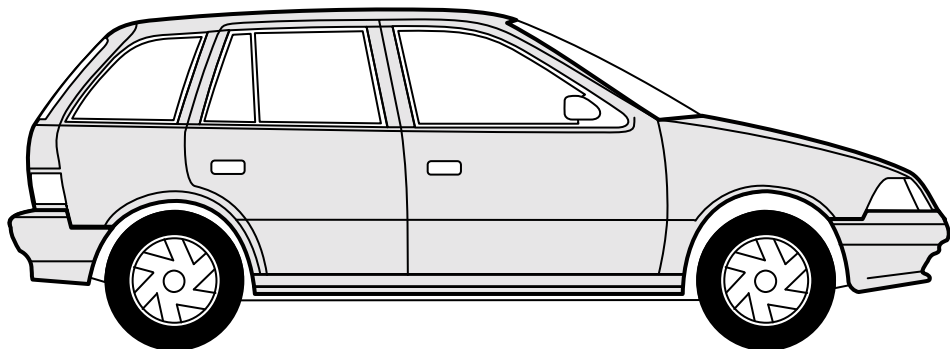
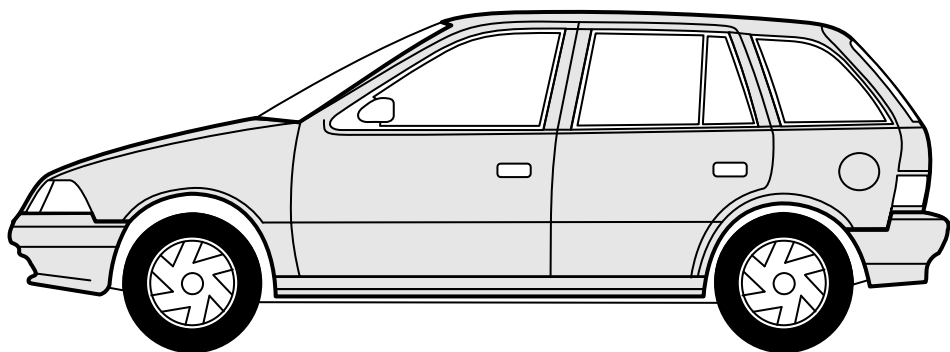
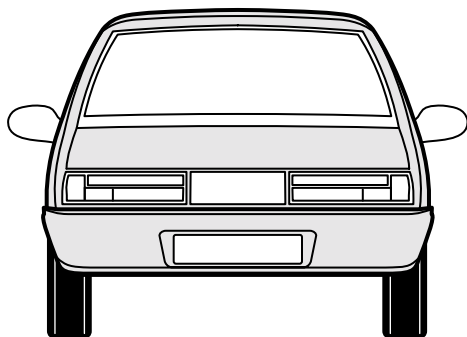
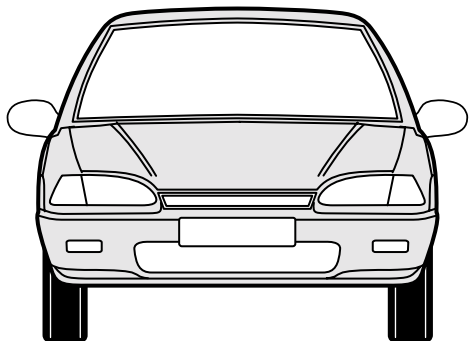

Suzu_017

Suzuki Vitara, kurz

1:30 L: 3.745 B: 1.695 H: 1.660 R: 2.200

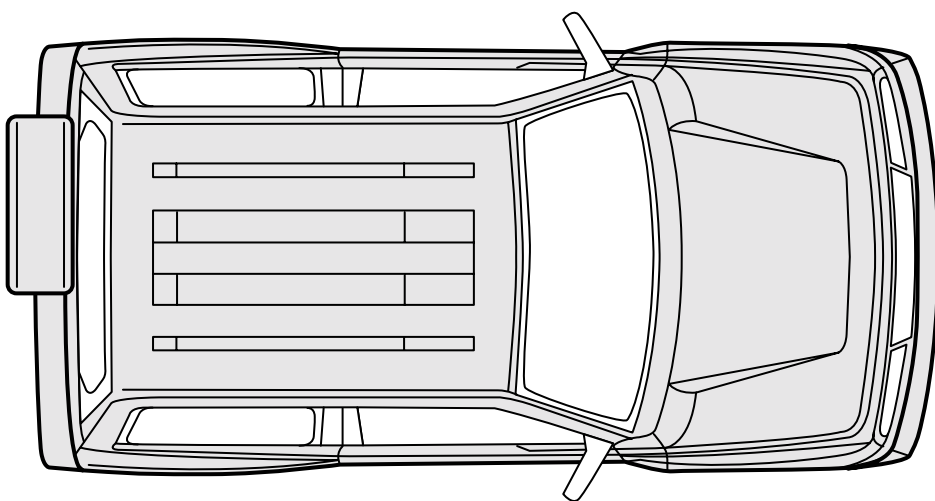
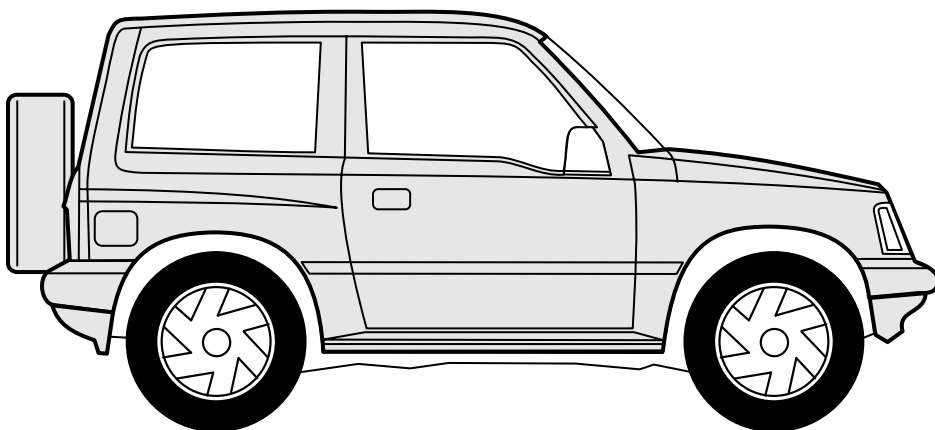
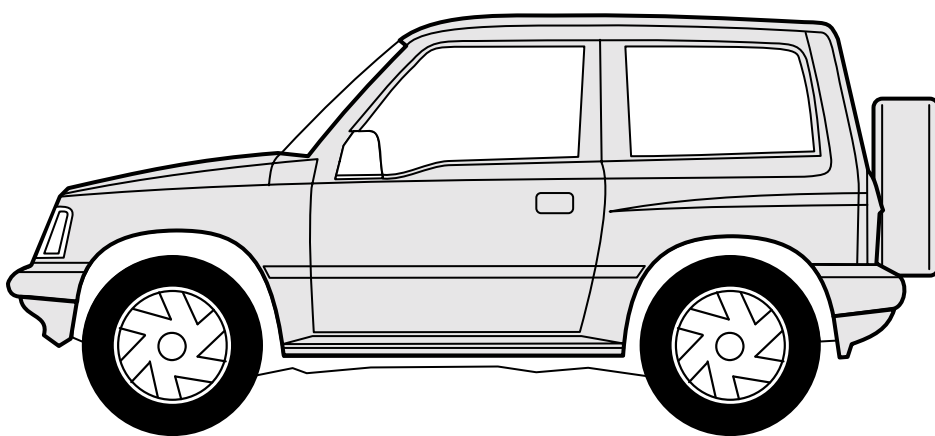
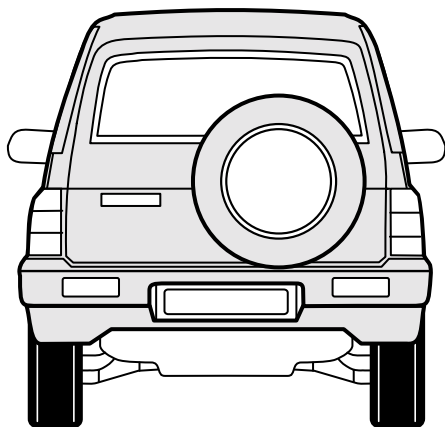
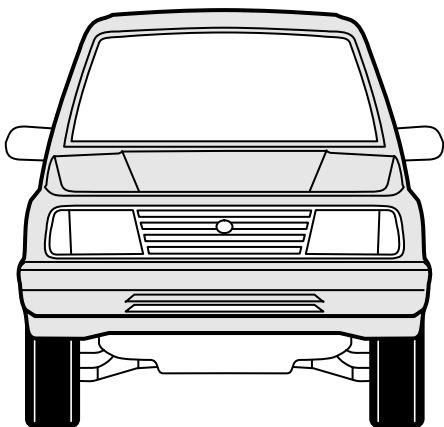

Suzu_018

Suzuki Vitara V6-2.0

1:30 L: 4.125 B: 1.695 H: 1.695 R: 2.480

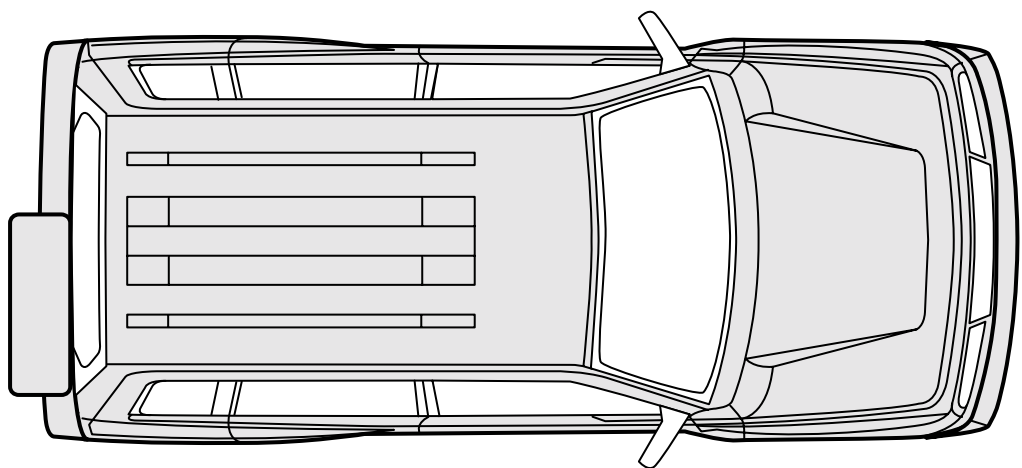
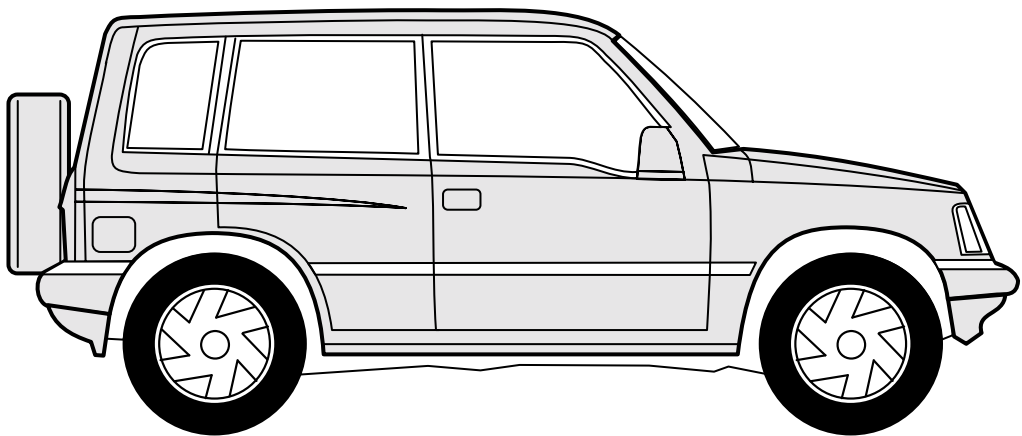
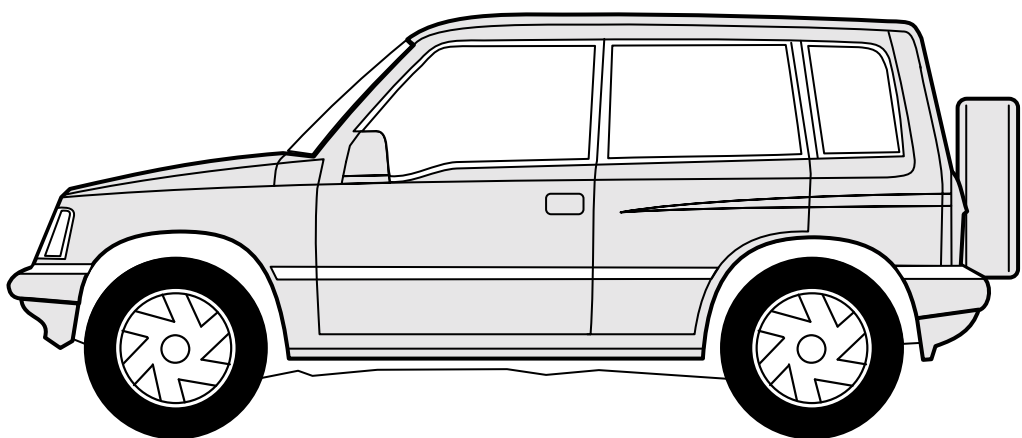
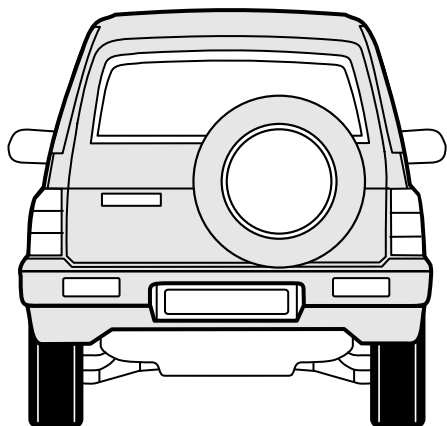
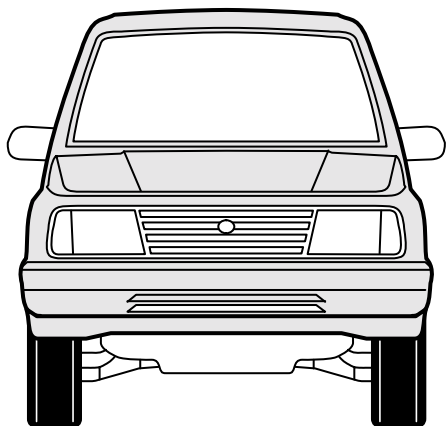

Suzu_019

Suzuki Vitara de Luxe, Cabrio

1:30 L: 3.632 B: 1.630 H: 1.665 R: 2.200

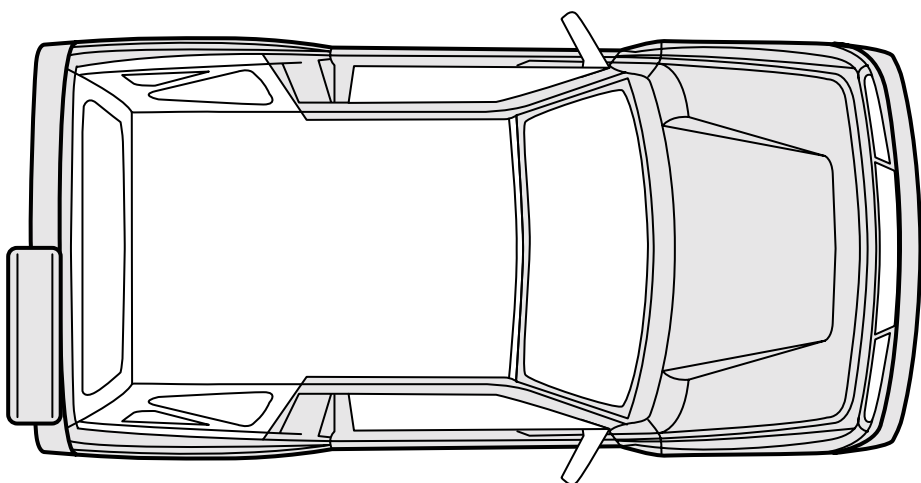
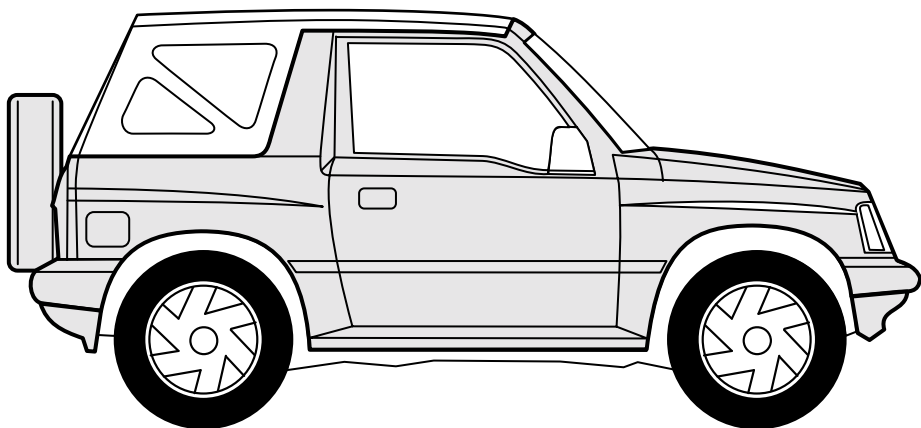
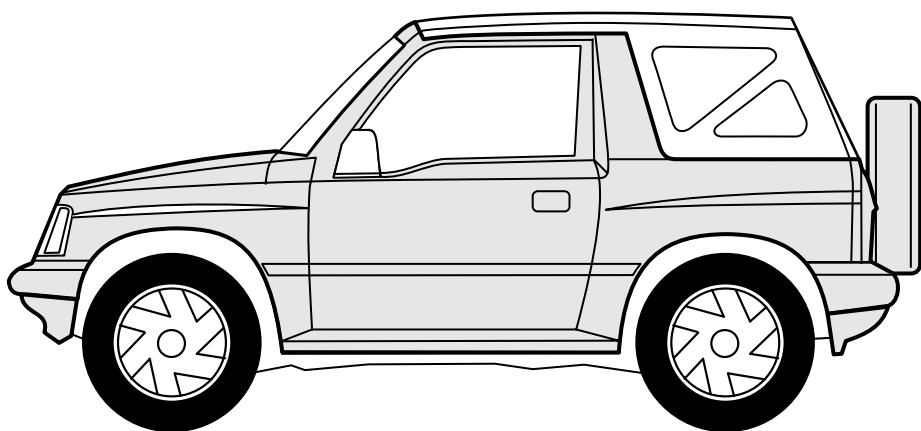
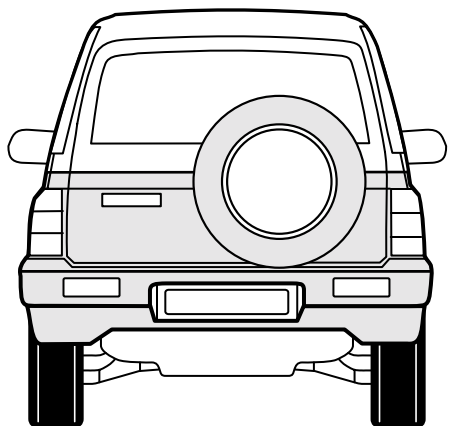
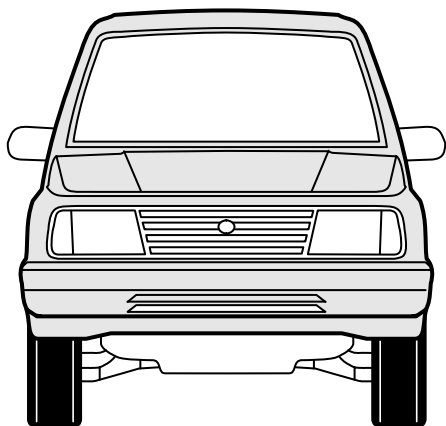

Suzu_020

Suzuki Wagon R+

1:30 L: 3.410 B: 1.575 H: 1.705 R: 2.335

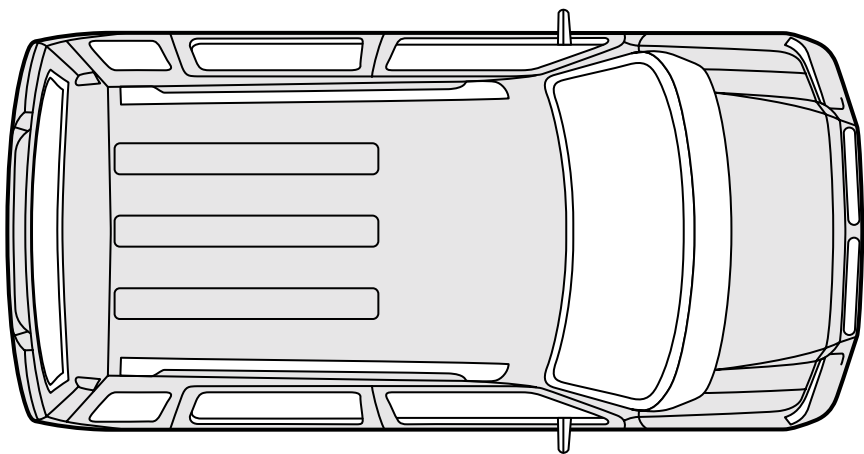
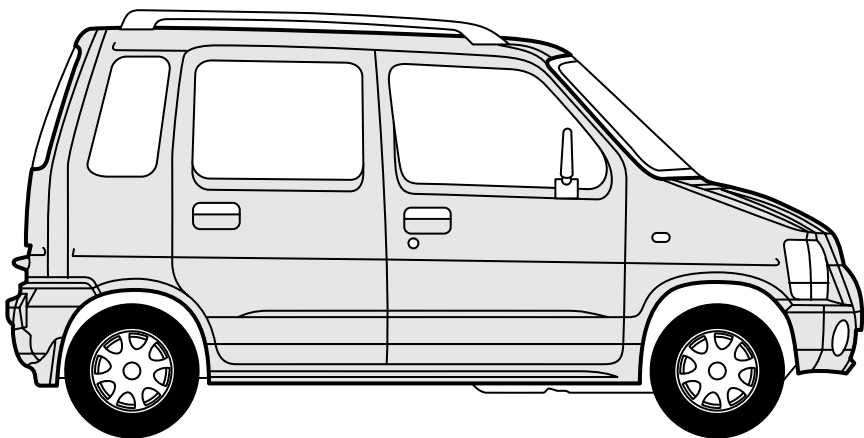
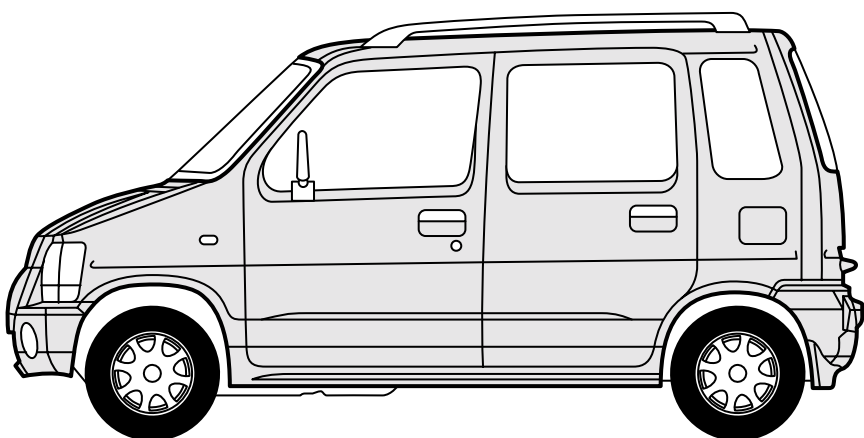
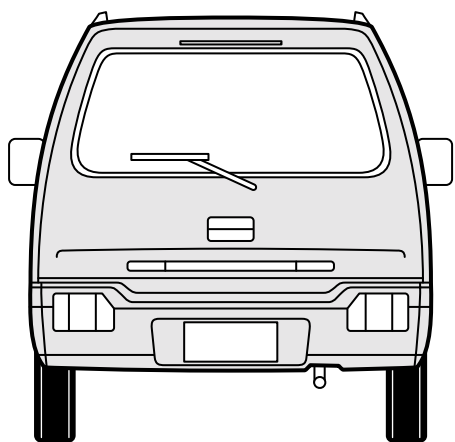
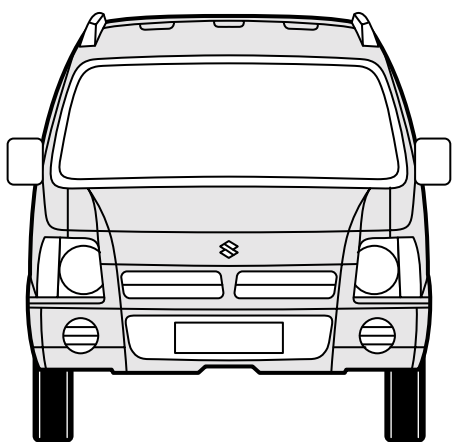

Suzu_021

Suzuki X-90

1:30 L: 3.710 B: 1.695 H: 1.555 R: 2.200

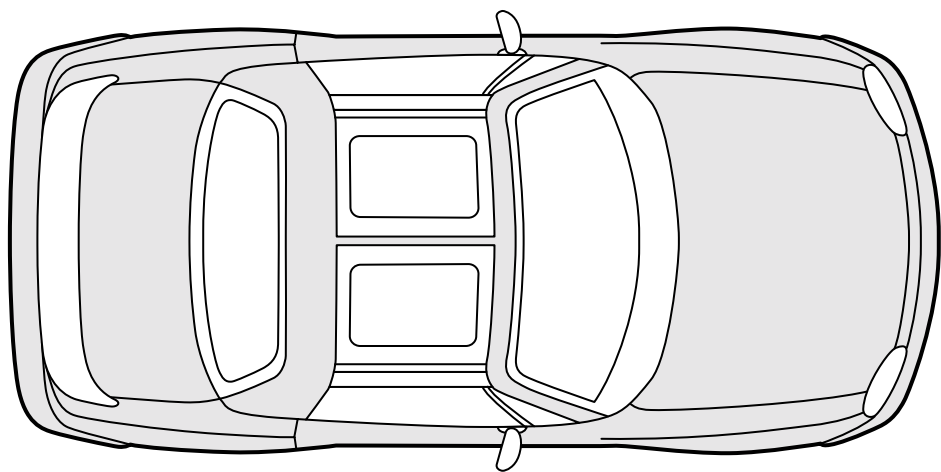
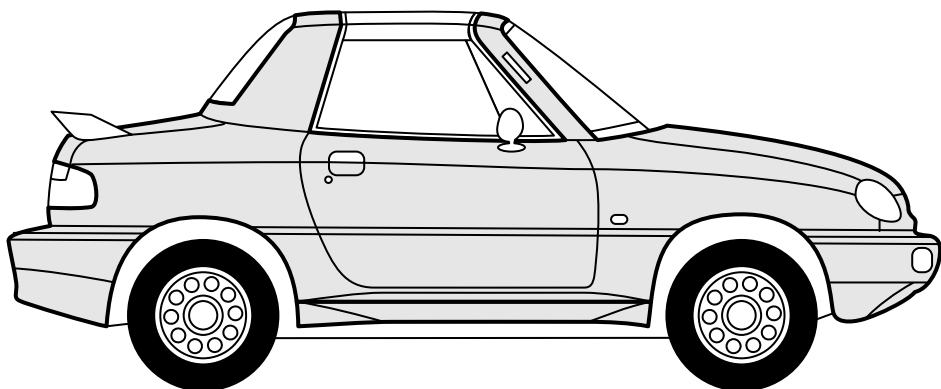
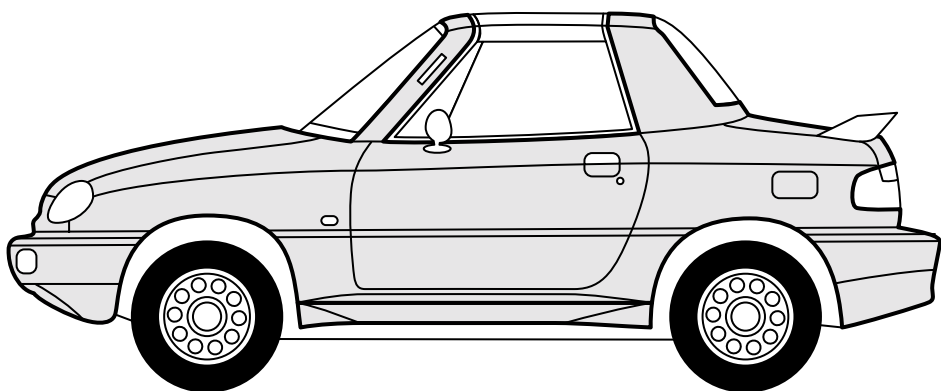
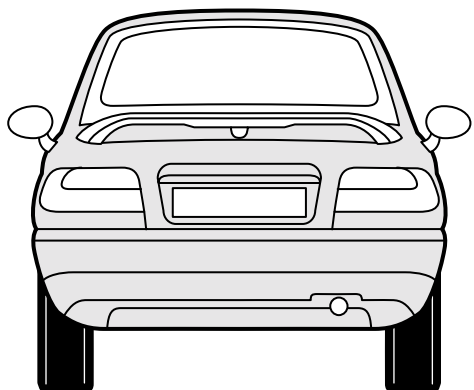
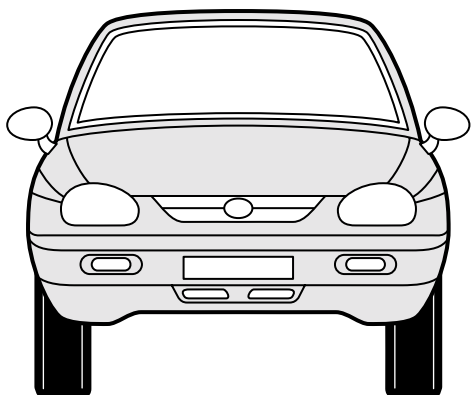

Suzu_022

Suzuki Grand Vitara, Cabrio

1:30 L: 3.875 B: 1.710 H: 1.690 R: 2.200

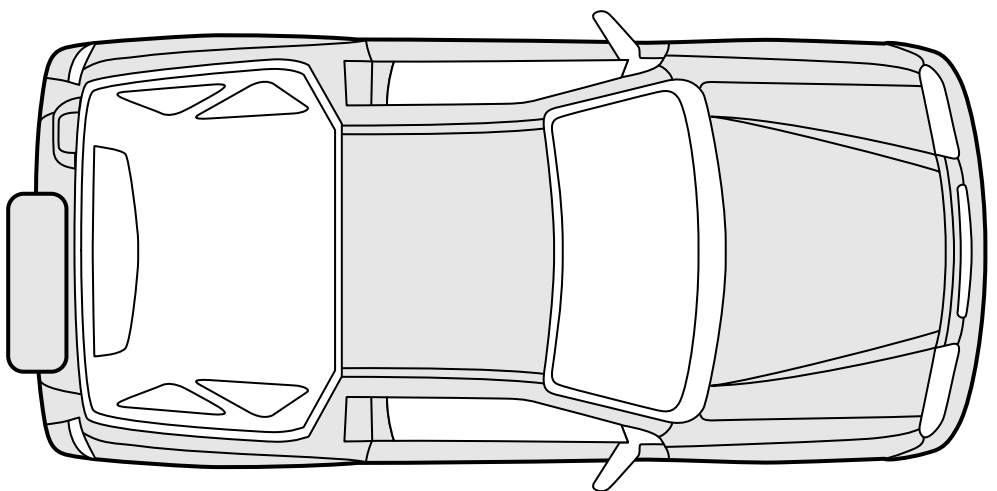
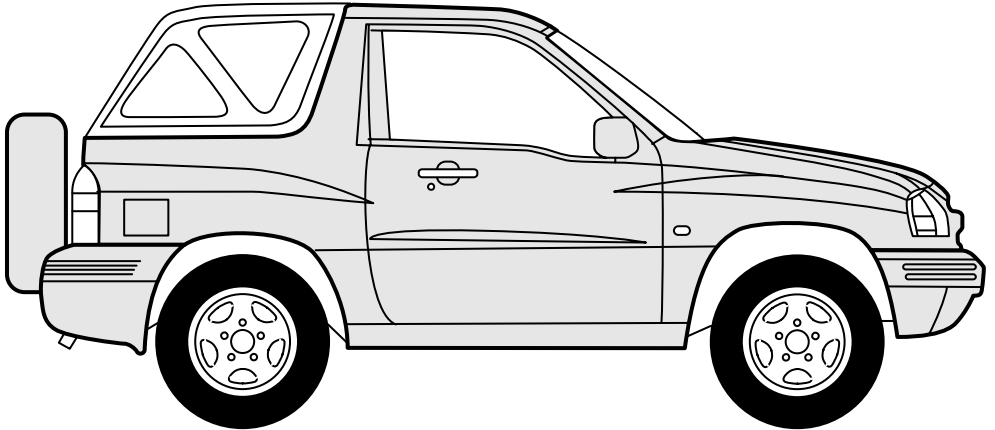
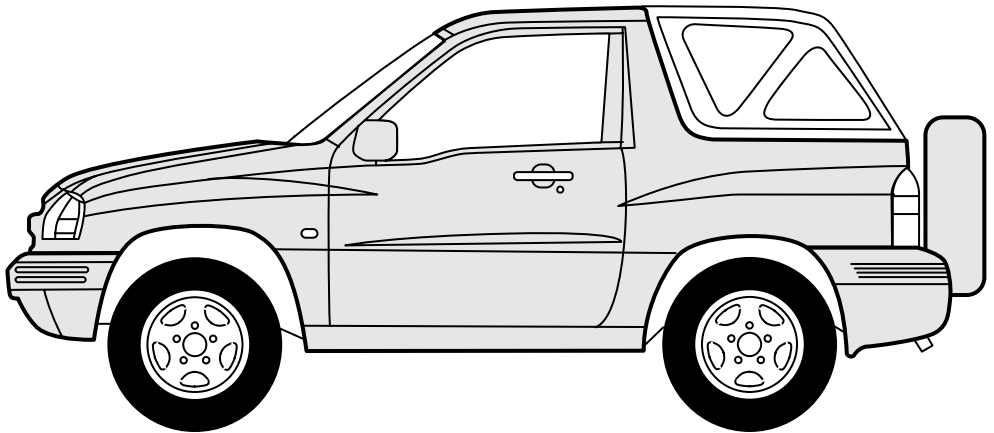
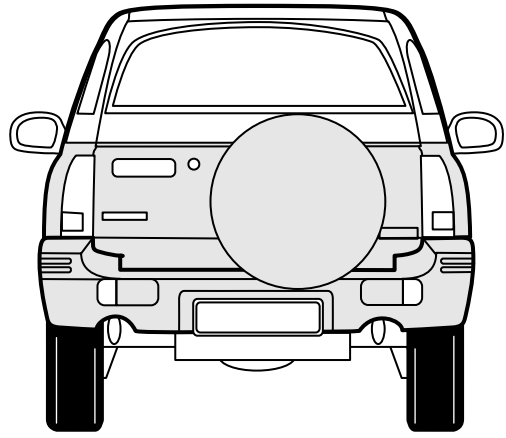
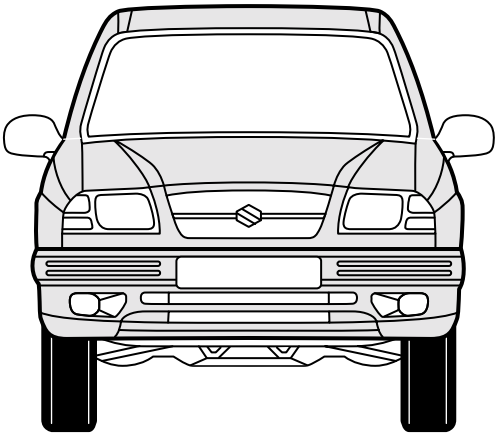

Suzu_023

Suzuki Jimny Cabrio

1:30 L: 3.625 B: 1.600 H: 1.665 R: 2.250

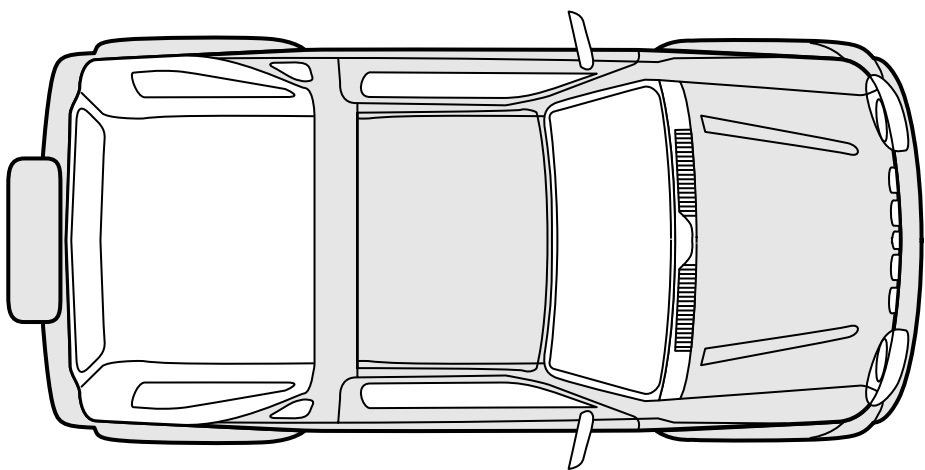
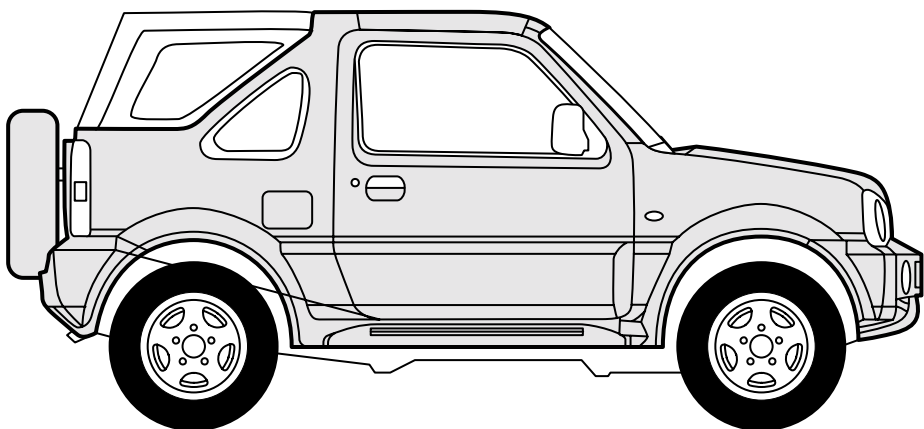
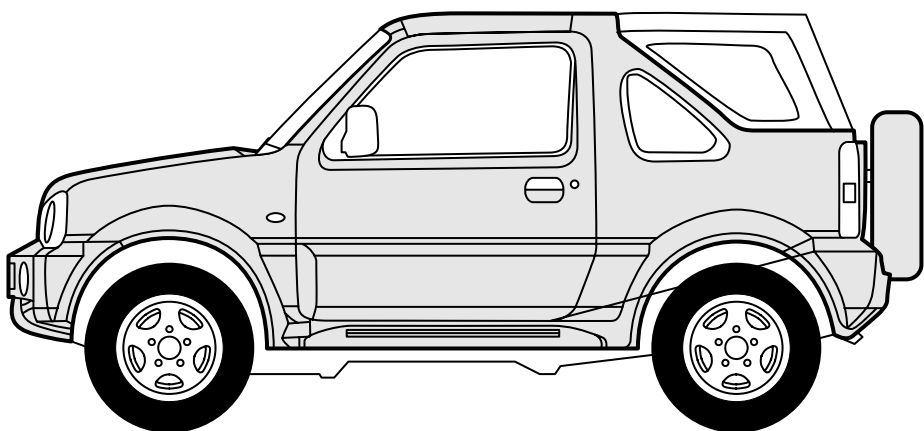
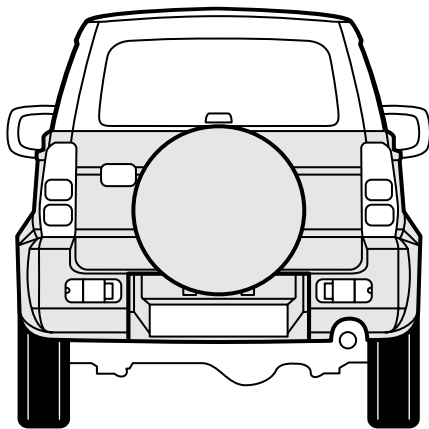

Suzuki Wagon R+ (1998)

1:30 L: 3.500 B: 1.620 H: 1.700 R: 2.360

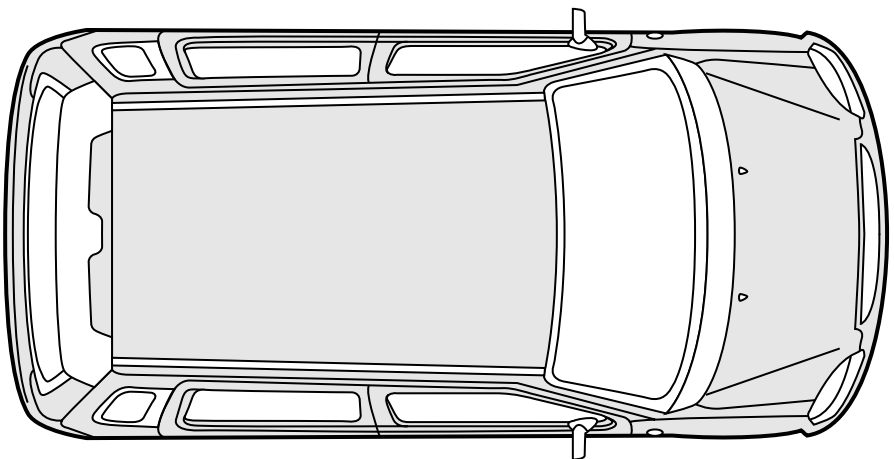
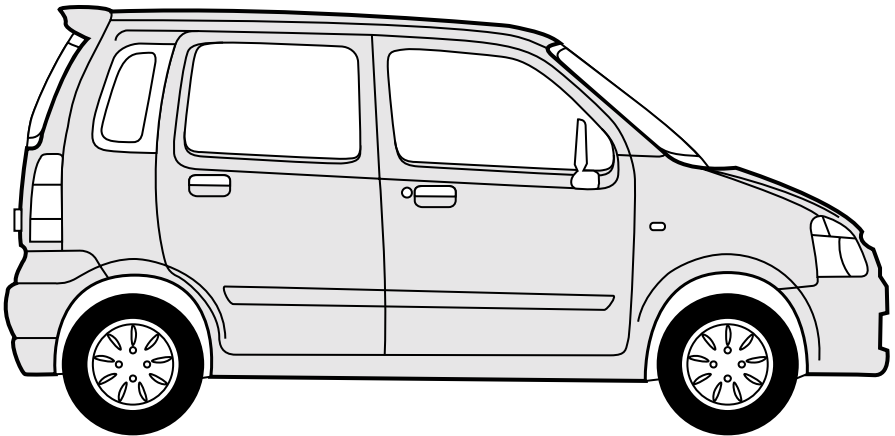
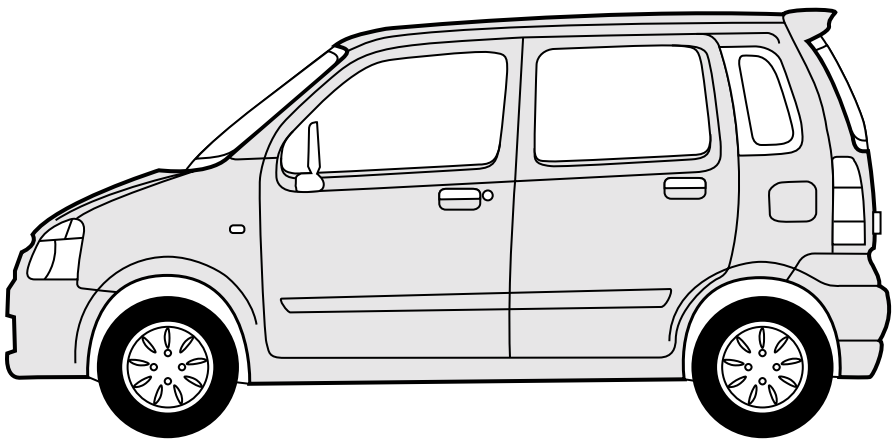
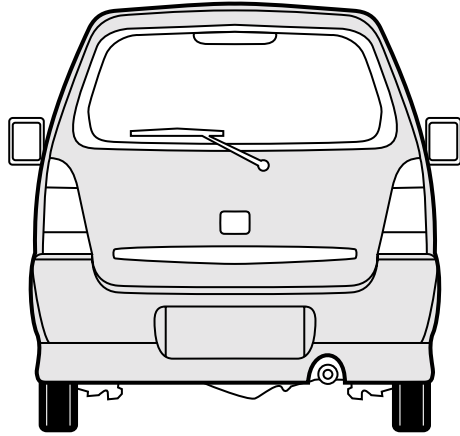
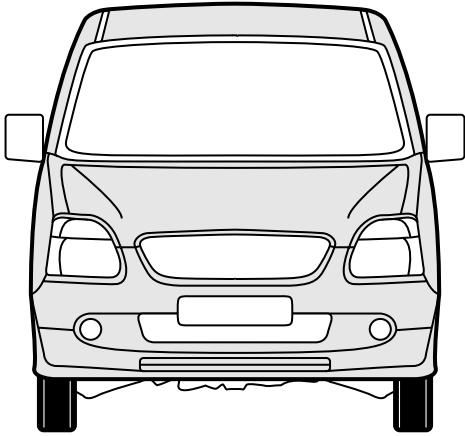

Suzu_025

Suzuki Ignis, 3-Tuerer (2001)

1:30 L: 3.615 B: 1.595 H: 1.540 R: 2.360

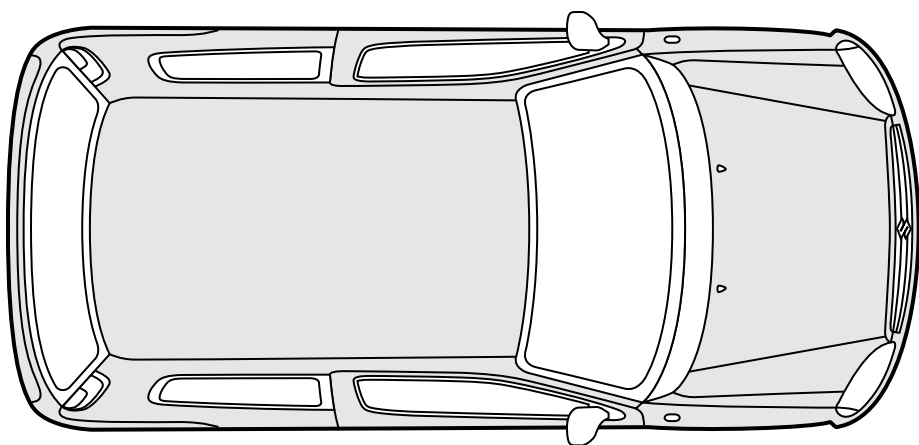
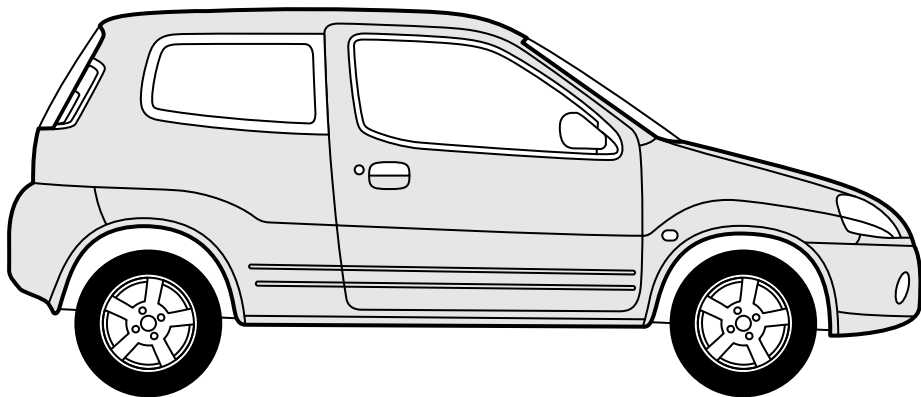
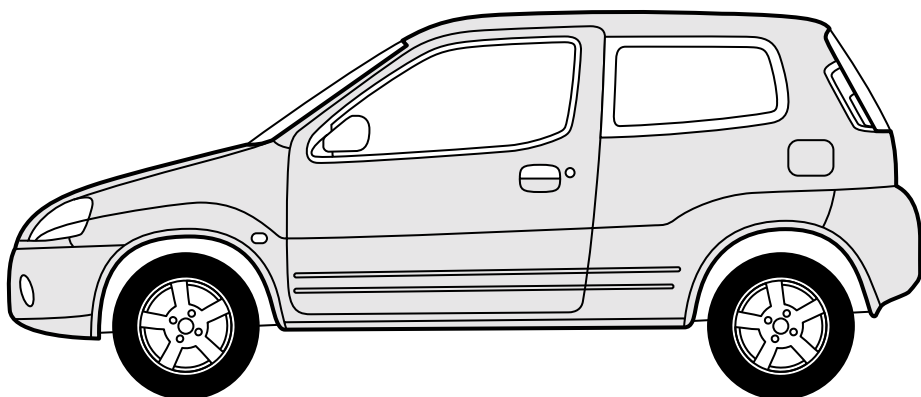
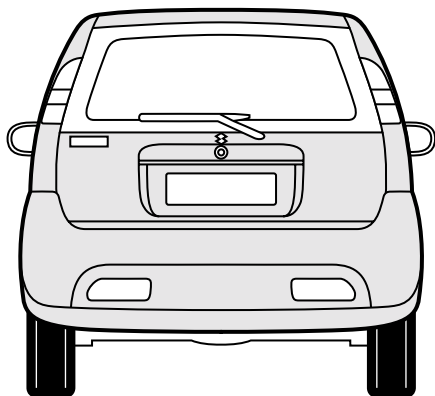
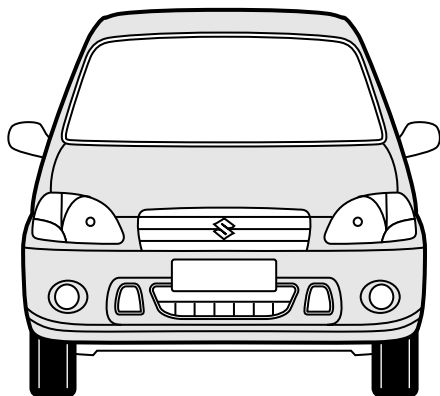

Suzu_026

Suzuki Ignis, 5-Tuerer (2001)

1:30 L: 3.615 B: 1.595 H: 1.585 R: 2.360

